

LONG-TERM DEVELOPMENT PLAN—2014

for Manitoba Hydro's Electrical Transmission System

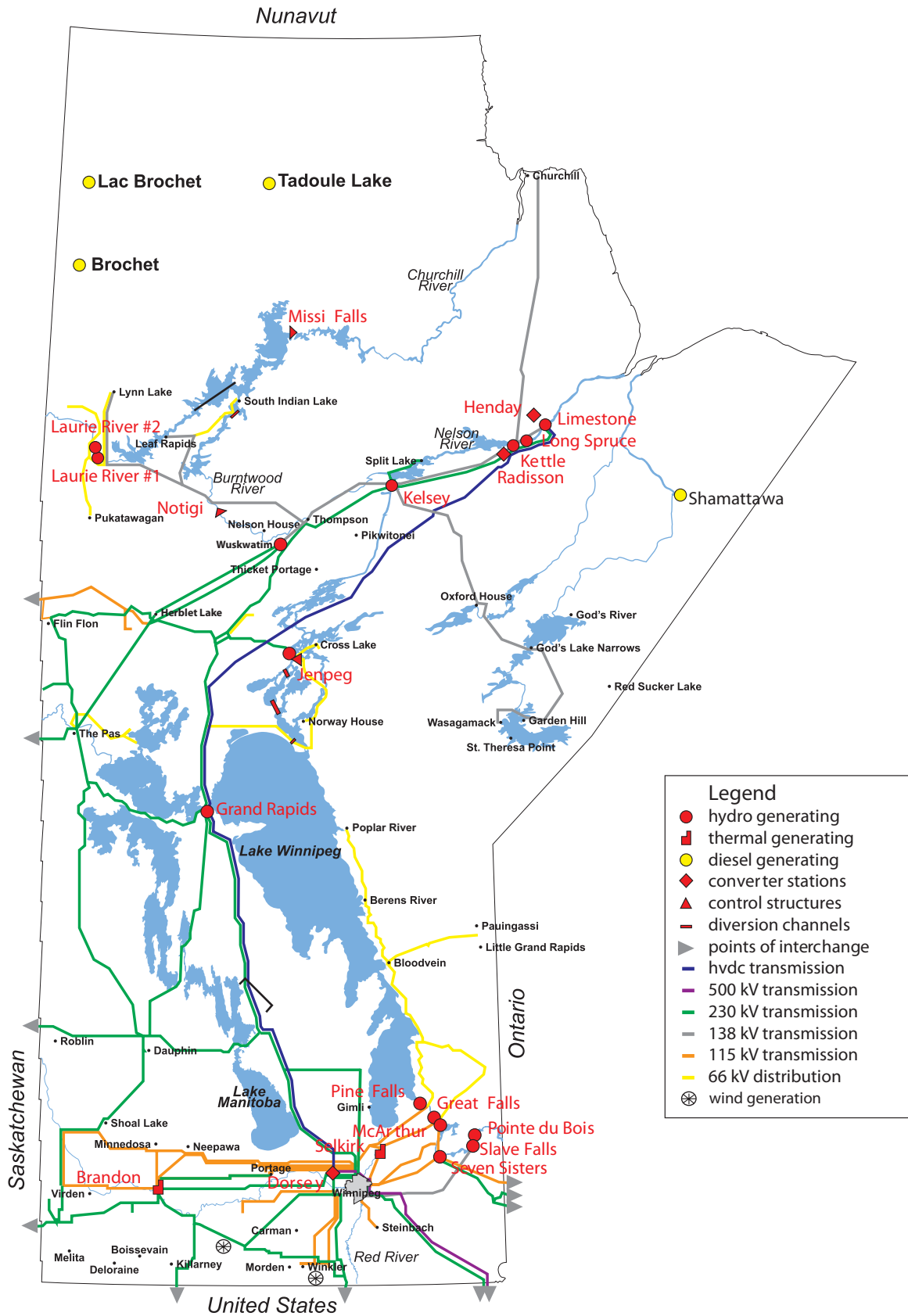

Manitoba Hydro's Existing Generating Stations and Transmission System



Executive Summary

The System Planning Department of Manitoba Hydro has prepared this long term plan for the Manitoba Hydro Electric Board's electrical transmission system, which links Manitoba Hydro's generating stations to a network of transmission and distribution lines across the province and beyond provincial boundaries. This is the current long term development plan for Manitoba Hydro's electrical transmission system generally covering the period from 2014 to 2033.

The plan proposes additions, enhancements, replacements, and repairs to ensure that the transmission system continues to meet Manitoba Hydro's mandate of serving the province with a reliable supply of electricity as well as meeting the performance requirements of Manitoba Hydro and its neighbouring utilities in Canada and the United States.

The bulk of Manitoba's power is transmitted from remote generators in the north to customers in southern Manitoba over the Nelson River HVDC transmission system. The HVDC system is a critical component for meeting the electricity needs of the province. The two Nelson River HVDC transmission lines are located on a common corridor, and both HVDC southern converters are located in the Dorsey HVDC converter station. This plan provides an overview of the plans Manitoba Hydro is formulating to increase the robustness of the HVDC transmission system to withstand extreme events such as fire, tornado or another weather event from disrupting this supply of northern generation.

To fulfill its vision to be recognized as a leading utility in North America with respect to reliability, Manitoba Hydro endeavours to continue to serve firm load for an outage of a transmission system element such as transmission line, transformer, circuit breaker, or any other auxiliary device. If a system element fails to function to its design specification for any reason, the network can be re configured so that affected area can be served from an alternate supply in most of cases. The transmission system is designed such that outages in one part of the network should not cascade or spread to neighbouring areas of the transmission system causing stress in other system elements. Achieving these goals often requires transmission system additions, replacements and enhancements. If these improvements are not completed in a timely manner, service to firm load customers would be greatly compromised.

To guide other departments at Manitoba Hydro and provide interested customers with an overview of efforts, the plan offers brief descriptions of 14 development projects, with varying in-service dates.

Riel Station reliability project will improve overall system reliability by adding an alternate terminal point for the existing 500 kV line transmission to the U.S., the Bipole III reliability project will provide an alternate north – south transmission path to the existing Interlake corridor and an alternate southern terminal. Transmission line refurbishments, re-construction of Scotland Station and Pointe du Bois line replacement projects are examples of addressing aging infrastructure in our system. Lake Winnipeg East system improvements will reduce the need for further system improvements to support area voltage. Establishment of Rockwood East 230/115 Station relieves transformer overloads in western Manitoba. Winnipeg to Brandon system improvements will provide the needed voltage support to increase system reliability. Establishment of Neepawa 230/66 kV Station will improve the under voltage driven by forecasted load growth in western Manitoba. Stanley Station 230/66 kV transformer addition will ensure a reliable supply of electricity to meet growing loads in south central Manitoba (Morden and Winkler area). Improvements of 115 kV south west Winnipeg transmission system is required in order to meet performance criteria for various contingency conditions. Construction of LaVerendrye to St.Vital 230 kV transmission line not only enables the 230 kV network in the Winnipeg area to withstand various and severe outages, but also improves its performance during normal operation and improves reliability of network in southern Manitoba. Construction of St.Vital to Letellier 230 kV transmission line is required to address contingency loading and low voltage concerns in south central Manitoba due to load growth. Keeyask generation outlet transmission facilities are needed to connect the generating station to the Manitoba Hydro grid.

Most of the projects are dictated by the need to expand the transmission system to reliably serve growing loads in Manitoba and transmit generation to the export markets. Other drivers of expansion are to improve safety, increase efficiency, replace aging facilities and connect new generation (see the table in next page).

The Transmission Business Unit is currently evaluating the status of the aging infrastructure in the Manitoba Hydro system and is going to develop long-term budget forecasts for its aging transmission system infrastructure requirements.

This Plan is reviewed and adjusted annually to reflect changing load forecasts and other circumstances. Not all of the proposed projects (most approved but some are pending approval) may be built. Some may be removed and replaced by other projects.

(Continued on next page)

Executive Summary (continued)

The new station sites and transmission lines associated with the projects described in this Plan are shown for illustrative purposes only. Manitoba Hydro follows a Site Selection and Environmental Assessment Process, which includes public consultation on the preferred location of new stations and routing of new transmission lines, and obtaining the regulatory licences necessary for construction of facilities.

Planned Major Transmission System Developments

DRIVERS of NEED

Improve Safety

Serve Load Growth

Reliability

Provide Transmission Service

Connect New Generation

Increase Efficiency

Aging Infrastructure

	Improve Safety	Serve Load Growth	Reliability	Provide Transmission Service	Connect New Generation	Increase Efficiency	Aging Infrastructure
1. Riel Station Reliability Project							
2. Bipole III Reliability Project							
3. Transmission Line Refurbishments							
4. Lake Winnipeg East System Improvements							
5. Rockwood East 230/115 kV Station							
6. Winnipeg to Brandon System Improvements							
7. Stafford (Scotland) Station Rebuild							
8. Neepawa 230/66 kV Station							
9. Stanley Station 230-66 kV Transformer Additions							
10. Pointe du Bois Transmission Line Replacement							
11. Improvements of 115 kV SW Winnipeg Transmission System							
12. La Verendrye to St. Vital 230 kV Transmission Line							
13. St. Vital to Letellier 230 kV Transmission Line							
14. Keeyask Generation Outlet Transmission Facilities							

Manitoba Hydro's Transmission Business Unit Mission Statement

To provide for the continuance of a supply of energy to meet the needs of the province and to promote economy and efficiency in the development, generation, transmission, distribution, supply and end-use of energy.

Table of Contents

Executive Summary	3	4. Transmission Development Planning for the Future	28
1. Introduction	7	4.1 Planning Process	28
2. Drivers of Need for New Transmission Facilities	9	4.2 Future Transmission Interconnections	29
2.1 Improve Safety.....	9	4.3 Access to Electricity Markets - Transmission Service	29
2.2 Serve Local Load Growth	9	4.3.1 Ontario Interface Transmission Services	30
2.3 Maintain and Improve Reliability	10	4.3.2 Saskatchewan Interface Transmission Services	30
2.4 Provide Transmission Service.....	11	4.4 Future Generation Interconnection	30
2.5 Connect New Generation	11	4.5 Wind Generation Interconnection	31
2.6 Increase Efficiency.....	11	4.6 Northern Exploratory Study	33
2.7 Address Aging Infrastructure.....	11	4.7 Major Customer Interconnection and Load Addition	33
3. Major Transmission System Developments	12	4.8 Addressing Aging Infrastructure.....	33
3.1 Riel Station Reliability Project	13	4.9 Northern Damping (Low Frequency Oscillations)	34
3.2 Bipole III Reliability Project	14	4.10 Future Transmission Corridors	35
3.3 Transmission Line Refurbishments	16	4.11 Resource Adequacy	36
3.4 Lake Winnipeg East System Improvements	17	Appendix	
3.5 Rockwood East 230/115 kV Station.....	18	1. Overview of Manitoba Hydro's Transmission & Distribution Facilities	37
3.6 Winnipeg to Brandon System Improvements	19	2. Generation and Transmission Proposed and Planned Projects Scheduled In-Service Dates.....	43
3.7 Stafford (Scotland) Station Rebuild.....	20		
3.8 Neepawa 230/66 kV Station.....	20		
3.9 Stanley Station 230-66 kV Transformer Additions	21		
3.10 Pointe du Bois Transmission Line Replacement.....	22		
3.11 Improvements of 115 kV SW Winnipeg Transmission System	23		
3.12 La Verendrye to St. Vital 230 kV Transmission Line	24		
3.13 St. Vital to Letellier 230 kV Transmission Line	25		
3.14 Keeyask Generation Outlet Transmission Facilities.....	26		

1. Introduction

The Long Term Development Plan - 2014 for Manitoba Hydro's Electrical Transmission System addresses future transmission system developments.

This 2014 plan reflects planned projects that have been approved in the 2013 Manitoba Hydro Capital Expenditure Forecast and those projects proposed for the 2014 Manitoba Hydro Capital Expenditure Forecast.

Manitoba Hydro is a provincial Crown Corporation providing electricity to 548,774 customers throughout Manitoba and natural gas service to 269,786 customers in various communities throughout southern Manitoba. Manitoba Hydro also has formal electricity export sale agreements with a number of electric utilities and marketers in the Midwestern U.S., Ontario, and Saskatchewan.

Nearly all electricity generated is from clean renewable waterpower. On average, about 33.1 billion kilowatt-hours of electricity are generated annually. Seventy-five percent is produced by five hydroelectric generating stations on the Nelson River; the remainder is generated at ten hydroelectric stations on the Winnipeg, Saskatchewan, Burntwood and Laurie rivers; two thermal stations; two independently owned wind farms and four diesel sites. The electricity is transmitted over nearly 100,000 kilometres of transmission and distribution lines.

Manitoba Hydro has 5725 MW of generation connected to its network. In addition, 116 MW of wind generation at St. Leon and 138 MW of wind generation at St. Joseph are available to Manitoba Hydro under power purchase agreements. In 2012, wind plants in Manitoba produced 875 GW.h, while in 2013 they produced 900 GW.h. Roughly 2.5% of Manitoba's annual energy generation is supplied by wind turbines.

In 2013, the corporation supplied a provincial gross total peak of 4535 MW (weather adjusted 4432 MW). The provincial peak load is growing at an average rate of about 1.6% per year (energy 1.6% per year).

The length of transmission lines connected to Manitoba Hydro's transmission network include the following:

- 1840 km of 500 kV transmission (HVDC)
- 210 km of 500 kV transmission (AC)
- 5000 km of 230 kV transmission (AC)
- 1400 km of 138 kV transmission (AC)
- 2900 km of 115 kV transmission (AC)

Manitoba Hydro plans additions and enhancements to its transmission and sub-transmission systems to ensure that the systems will continue to operate acceptably in the future, as the requirements change.

Manitoba Hydro expects its transmission system to meet performance requirements set out in the following:

- North American Electric Reliability Corporation (NERC) Reliability Standards
- Manitoba Hydro's own Transmission System Interconnection Requirements (TSIR), which defines standards for system adequacy, reliability, and security.

From Generating Stations to Customers

The major transmission system is a network of high voltage transmission lines used to move electrical power over long distances, from generating stations to terminal stations.

At terminal stations, electrical power is transformed down to mid-range voltages and sent over a network of sub-transmission system lines to groups of distribution stations.

At each distribution station power is transformed to lower voltages and distributed over the distribution system feeder lines (either overhead pole lines or underground cables) to distribution transformers. Each distribution transformer transforms the voltage to lower user voltages, to directly feed a customer or a cluster of customers.

Voltage Ranges:

- Generating Stations: 4 kV to 15 kV
- HVDC \pm 463.5 kV, \pm 500 kV
- Northern Transmission: 138 kV, 230 kV
- Southern Transmission: 115 kV, 230 kV, 500 kV
- Sub-transmission: 33 to 66 kV
- Distribution: 4 kV to 24 kV

Note: 1 kV is 1,000 volts

1. Introduction (continued)

These standards and criteria are used to develop system addition and enhancement plans. Numerous transmission system developments comprise this plan.

Each of the 14 developments discussed has one or more drivers of need, which are described in detail in Chapter 2.

Developments are highlighted in Chapter 3, with brief descriptions, expected in-service dates, and other details that provide a clear summary of the projects.

Currently, there are several proposed utility transmission and generation developments that may be approved by Manitoba Hydro. In addition, subject to studies, many independent generation developers, primarily wind, have asked to connect their facilities to Manitoba Hydro's transmission system, so that the electricity they generate can be marketed under Manitoba Hydro's Open Access Transmission Tariff. For the sake of completeness, the major proposed utility transmission and generation developments, although not finalized, are also briefly reviewed in Chapter 4.

Manitoba Hydro's existing transmission facilities are outlined in Appendix 1. Appendix 2 summarizes a list of Generation and Transmission projects including estimated in-service dates.

This document is the current Long Term Development Plan for Manitoba Hydro's electrical transmission system. Subsequent development plans will be issued annually to reflect changing circumstances such as changes in customer demand, the need for reliability enhancements, request for transmission service, or the addition of new generator connections, addressing aging infrastructure or regulatory requirements.

Section 4.8 of this plan provides insight into a long-term (10 years) strategy to replace aging transformers, circuit breakers and wood pole transmission structures.

The Long Term Development Plan will be posted on Manitoba Hydro OASIS website, which can be found on the Manitoba Hydro web page (<http://www.hydro.mb.ca>), then by clicking on Transmission Tariffs for Energy Supplies and Power Producers, under Your Business tab, and then selecting either the Transmission Tariff Link or Interconnection Tariff Link to get to the Manitoba Hydro OASIS page (<http://www.oasis.oati.com/MHEB/index.html>). The Long Term Transmission Plan is located under the System Information tab.

2. Drivers of Need for New Transmission Facilities

Manitoba Hydro recognizes seven drivers of need in determining additions, enhancements, repairs and replacements required to its transmission system. Each of the 14 projects highlighted in this plan reflects one or more of these drivers, but not necessarily all seven of the drivers.

2.1 Improve Safety

Safety is Manitoba Hydro’s first priority and most important goal. Manitoba Hydro’s vision is to be recognized as the best utility in North America with respect to safety.

Manitoba Hydro is committed to protecting the public and its employees from personal injury by maintaining and operating the transmission system in a safe manner. This commitment involves modifying existing circuit protection schemes, implementing new protection schemes, and periodically replacing or upgrading aging infrastructure to meet changing conditions. Circuit protection schemes are installed to minimize the probability of equipment failure and personal injury. Transmission lines are upgraded to ensure adequate clearance between the energized conductors and ground level.

2.2 Serve Local Load Growth

Forecasted provincial load growth is used to determine the need for transmission system additions and enhancements. Expected provincial load growth is detailed in a corporate “20 Year Electric Load Forecast”. Developed annually, the Electric Load Forecast predicts provincial electric load growth for the next 20 years in various load sectors, including residential, general service, area and roadway lighting, construction power, and station service. Electric Load Forecast predictions are based on historical billing data and the current economic and energy price outlook and planned corporate demand side management targets.

Manitoba’s annual electrical energy forecast includes all electrical energy required yearly to meet the gross firm energy requirements of customers in the province. It is predicted to increase from 25,239 GW.h in 2013/2014 to 32,667 GW.h in 2032/2033, for an average annual growth rate of 1.5%.

The province’s yearly gross peak power requirement is the maximum power produced during the year to meet the power requirements of customers in Manitoba. It is predicted to increase from 4601 MW in 2013/2014 to 5959 MW in 2032/2033, for an average annual growth rate of 1.5%.

Manitoba's gross firm electrical energy requirements. Provincial loads are expected to grow by 1.5% a year between 2013/2014 and 2022/2023 (Reference: 2013 Electric Load Forecast)

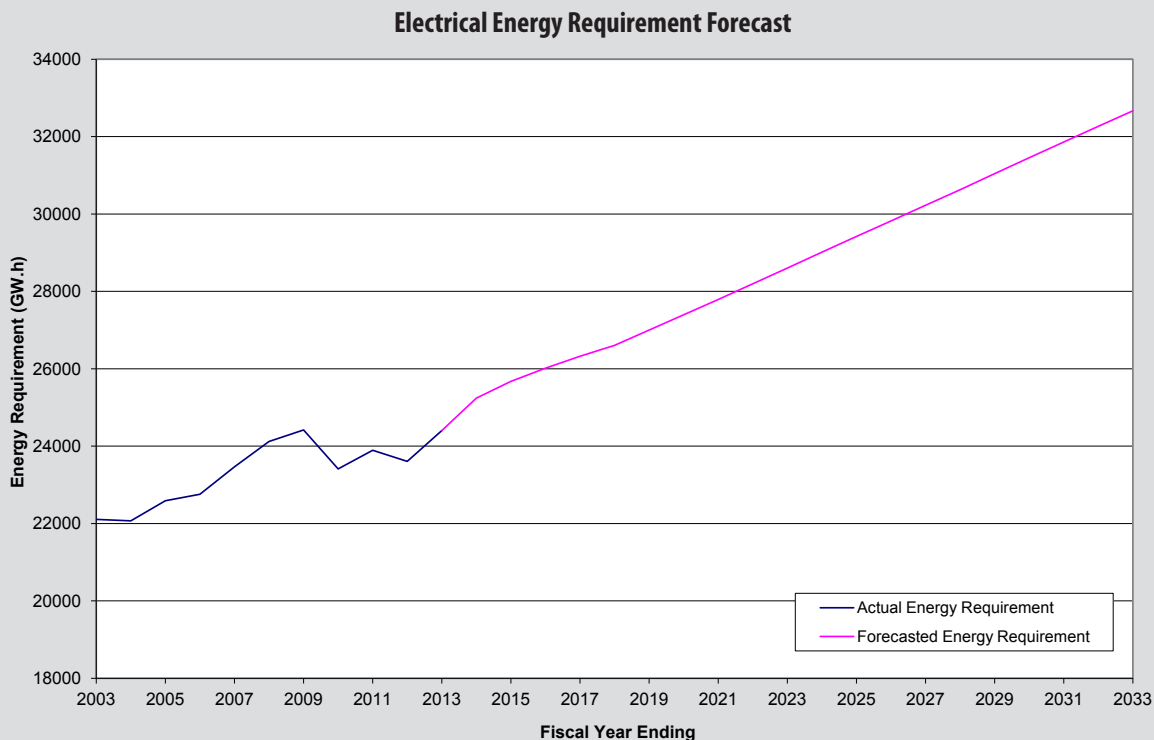

2.2 Serve Local Load Growth (continued)

New major customer loads requiring up to 500 kW of power can generally be supplied by the distribution system, whereas new major loads requiring more than 5000 kW of power will likely need to be supplied by the high voltage distribution system or network transmission system. Technical requirements for connecting generators and loads to the high voltage distribution or network transmission systems are defined in Manitoba Hydro's "Transmission System Interconnection Requirements", also available on Manitoba Hydro's website which can be found on the Manitoba Hydro web page (<http://www.hydro.mb.ca>), then by clicking on Transmission Tariffs for Energy Supplies and Power Producers, under Your Business tab, then selecting either the Transmission Tariff link or Interconnection Tariff link to get to the Manitoba Hydro OASIS page (<http://oasis.midwestiso.org/oasis/mheb>).

2.3 Maintain and Improve Reliability

To fulfill its vision to be recognized as the best utility in North America with respect to reliability, Manitoba Hydro endeavours to continue serve firm load for an outage of a transmission system element such as transmission line, transformer, circuit breaker, or any other auxiliary device. If a system element fails to function to its design specification for any reason, the network can be re-configured so that affected area can be served from an alternate supply in most of cases. The transmission system is designed such that outages in one part of the network should not cascade or spread to neighboring areas of the transmission system causing stress on other system elements. Achieving these goals often requires transmission system additions, replacements and enhancements. If these improvements are not completed in a timely manner, service to firm load customers would be greatly compromised.

Manitoba Hydro regularly conducts system simulation studies to assess the performance of the existing system against reliability standards and to determine what transmission system improvements are required to maintain system reliability.

*Manitoba's gross total peak electrical power requirements. Peak provincial power is expected to grow by 1.5% between 2013/2014 and 2022/2023
(Reference: 2013 Electric Load Forecast Report)*

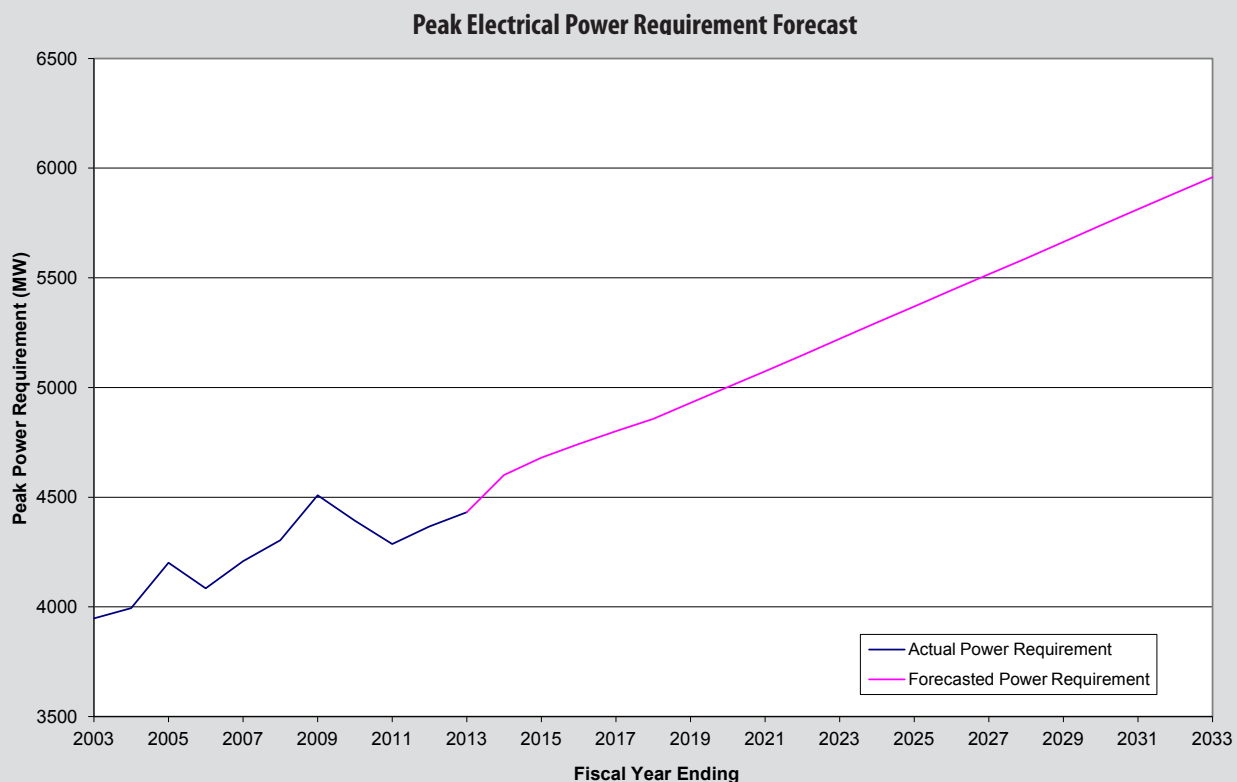

2.3 Maintain and Improve Reliability (continued)

Manitoba Hydro expects its transmission system to meet the provincially legislated performance requirements of the North American Electric Reliability Corporation (NERC) standards, and its own Transmission System Interconnection Requirements.

2.4 Provide Transmission Service

Transmission system improvements may be required to provide or maintain transmission service under Manitoba Hydro's Open Access Transmission tariff. In addition Manitoba Hydro receives numerous requests for seasonal firm service and short term non-firm service, all of which are posted on the Manitoba Hydro website. (see section 4.3)

Export Sales: Manitoba Hydro currently has long term firm export sales agreements with utilities in Minnesota, Wisconsin and Saskatchewan.

Import Purchases: Manitoba Hydro plans its generation resources based on hydraulic generation available during the lowest river flows on record. The hydraulic generation is augmented by Manitoba Hydro thermal generation and imports.

Manitoba Hydro secures imported power during the winter season. The Corporation's predominantly hydraulic generation system usually produces surplus energy during the summer season, when river flows are generally normal or above normal. Peak Manitoba loads occur in winter.

Import purchase agreements are also used to provide energy during periods of drought.

2.5 Connect New Generation

Generation within the province may be connected to the Manitoba Hydro transmission, high voltage transmission or distribution system, in accordance with the terms and conditions of the Manitoba Hydro's Open Access Interconnection Tariff (OAIT), posted on the Manitoba Hydro website (see section 4.3).

Manitoba Hydro conducts system studies to determine what enhancements or additions to the network will be required to connect new generation. Major generation can be connected to the transmission system with minor transmission additions only if the generation is close to major load centres or if the generation results in reversed or reduced flows on the existing transmission network.

Currently, there are several generation developments that may be interconnected with Manitoba Hydro's system. The Wuskwatim Generating Station, a new three unit, 214 MW station on the Burntwood River near Thompson has been recently completed and connected to the Manitoba Hydro network. Other interconnection projects include Kelsey re-running and 695 MW Keeyask Generating Station. A 138 MW wind farm at St. Joseph, which has been connected to the network in 2011. An additional 16 MW of wind capacity has been added at St. Leon to the existing wind farm in 2012.

2.6 Increase Efficiency

A corporate mission is to provide cost effective transmission. Manitoba Hydro conducts system simulation studies to determine feasible transmission system improvements for efficient energy transmission and reduced power losses. Bipole III will provide increased efficiency by means of reducing HVDC transmission losses in Manitoba's three HVDC bipoles. Transmission voltage upgrades have also been implemented to reduce losses.

2.7 Address Aging Infrastructure

Replacement or repair of aging infrastructure is often required to attain a reliable transmission system. Refurbishment of aging transmission lines, the reconstruction of high voltage transmission circuits and the replacement of circuit breakers that have reached their end-of-life are examples. Re-construction of Scotland Station, Pointe du Bois line upgrades, and replacement of St. James station, are further examples. Manitoba Hydro's Transmission business unit has also started a condition assessment program for its major assets and, based on initial results, has established sustaintment programs for its transformer, circuit breaker and transmission line wood pole structure assets as part of its capital plan to fund proactive replacements and refurbishments.

3. Major Transmission System Development

The following projects reported in the 2013 plan have been completed:

- Cornwallis 230/115 kV new 4th Transformer bank
- Transmission service for Kelsey Re-running Project
- Transmission service for Great Falls Re-running Project
- Keewatinohk Construction Power Station for Bipole III
- BE3 115 kV line reconductoring
- Brandon G.S. - Cornwallis 115 kV - New line CB4
- Transcona East 230/66 kV Station
- Lettelier Hot Standby (Enbridge Clipper Phase II)
- Over the past year, the HVDC converter Request for Proposal (RFP), both the Keewatinohk and Riel sites was issued. The RFPs on the HVDC line components, including towers, insulator, conductors, hardware were also released. An Environment Act License was received in August 2013. Work continues toward fulfilling pre-construction conditions, obtaining permits, and easements. The work permits were received for several HVDC line components of Bipole III and construction power station, and the construction has started.

Transmission refurbishments are being planned in many areas of the province. The need for line refurbishments has been further heightened by the NERC Alert requiring field verification of transmission line ratings. The new Neepawa station is nearing its completion with I.S.D. of March 2015. Plans are in place at Stanley for the permanent installation of the Hot Stand-by bank as well as a third transformer bank. The concept described under “Selkirk Area Improvements” in the previous 2009 plan has been changed to construct a new 230/115 kV station at Rockwood to improve system reliability and to serve load growth.

The concept described under “Pine Falls-Bloodvein 115 kV Transmission Improvement” in previous year’s plan has been changed to construct a new 115 kV line and a new 115/66 kV station at Manigotogan.

The following transmission system developments presented in Sections 3.1 to 3.14, approved in Manitoba Hydro’s Capital Expenditure Forecast, are required to keep the transmission system operating reliably. While these represent the bulk of projects, numerous smaller enhancement projects are also included in the Capital Plan. A complete list of these projects are listed in Appendix 2.

The project diagrams included with the project descriptions in Sections 3.1 to 3.14 are conceptual diagrams. As such, these diagrams do not illustrate transmission facility siting or routing. Manitoba Hydro follows a Site Selection and Environmental Assessment process to select locations for new stations and routes for new transmission lines as discussed in Section 4.1.

3.1 Riel Station Reliability Project

D602F, a 500 kV line, now connects the Dorsey 500 kV AC Station, north of Winnipeg, to Forbes Station near Hibbing, Minnesota in the U.S. A new station, Riel, is being built just east of Winnipeg adjacent to the right of way of the 500 kV line.

The Riel Station currently under construction is located on the southeast Winnipeg periphery adjacent to major 230 kV and 500 kV transmission corridors, making it an ideal location for a new supply point for Winnipeg load.

The location minimizes the need for new transmission corridors into and out of Riel and reduces the amount of new west to east transmission across Winnipeg as it provides an alternate supply point to Dorsey, which is located on the northwest periphery of Winnipeg.

The project includes establishing the Riel Station site, installing 230 kV and 500 kV switch yards, installing a 1200 MVA, 230 kV to 500 kV transformer bank, sectionalizing the existing Dorsey-Forbes 500 kV line¹, sectionalizing two existing 230 kV lines (Ridgeway-St. Vital lines R32V and R33V), and installing 500 kV line reactors.

The project will improve system reliability by adding an alternate terminal point for the existing 500 kV transmission line to the U.S., thereby preserving Manitoba Hydro's system import capability under adverse conditions. The station went into service in October 2014.

¹ Sectionalizing the existing Dorsey-Forbes line means cutting the line at Riel and terminating it at Riel to form a Dorsey-Riel line and a Riel-Forbes line.

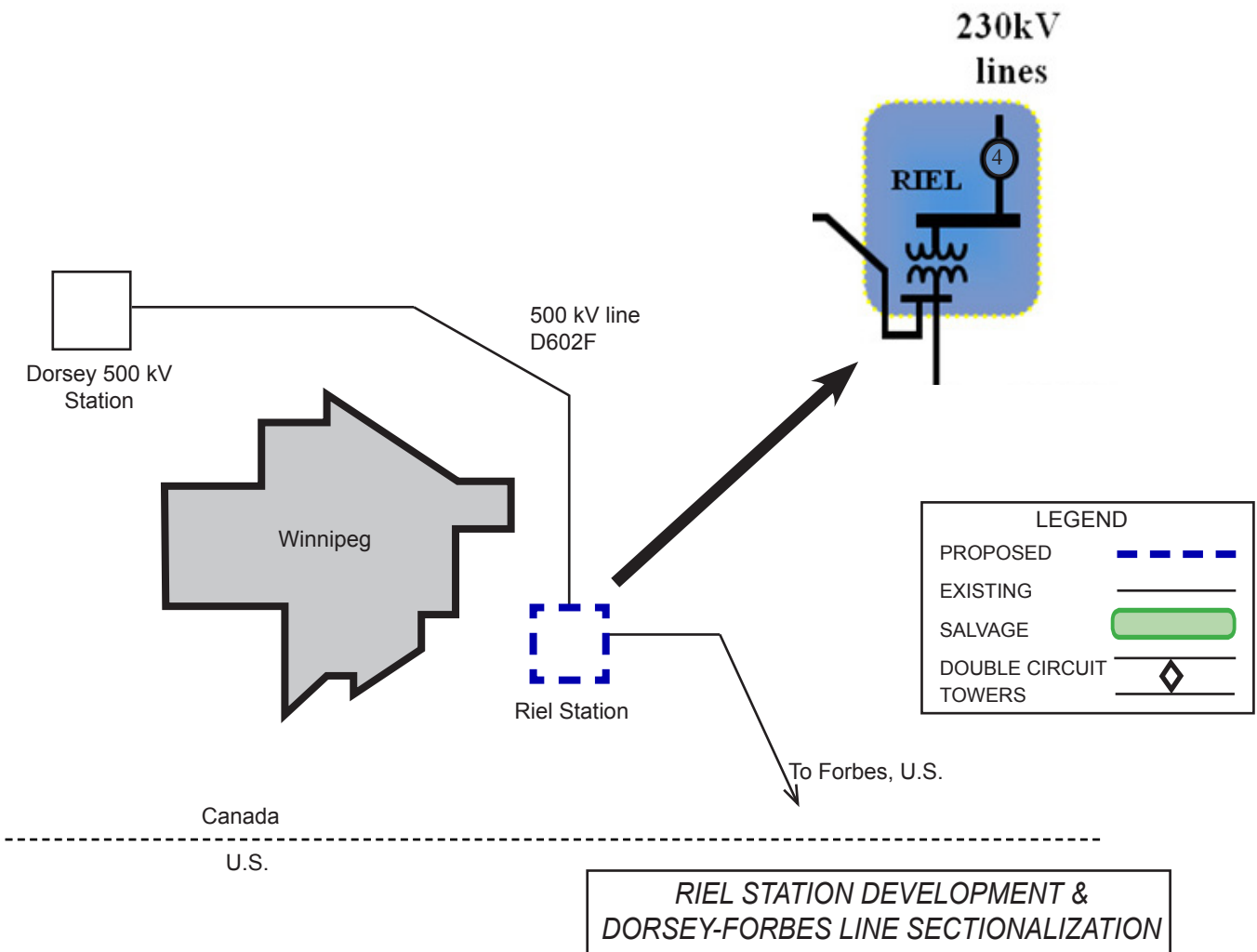

3.2 Bipole III Reliability Project

Enhancement of the reliability and security of HVDC transmission lines and the Dorsey Converter Station has been under investigation for some time. The HVDC transmission lines, Bipoles I and II, are located on a common right-of-way corridor referred to as the Interlake corridor which is 895 km in length.

The southern converters of Bipole I and II are both located in the Dorsey Converter Station. The Bipole I & II corridor and the Dorsey Station are vulnerable to low probability, but severe events such as fire, wind bursts, tornados and ice storms; that could cause extended outages creating severe hardship to Manitoba Hydro customers and Manitoba. One such event occurred on September 6, 1996 when straight line winds associated with a microburst resulted in the collapse of 19 HVDC transmission towers immediately north of the Dorsey Converter Station taking both the Bipole I and II out of service.

Manitoba Hydro has evaluated various alternatives for enhancing the reliability of the HVDC transmission, namely the addition of gas turbines in southern Manitoba, the purchase of USA generation via a new 500 kV import line and a Bipole III scheme. Manitoba Hydro selected the Bipole III scheme as the preferred reliability enhancement project.

The Bipole III scheme with a west side of the province routing currently includes:

- a ± 500 kV 2000MW HVDC transmission line (west of Lake Winnipegosis and Lake Manitoba), about 1384 km long, from Keewatinohk Converter Station to Riel Converter Station
- a 2000 MW converter station in the north (Keewatinohk Converter Station);
- One 52 km 230 kV transmission line from Long Spruce to Keewatinohk and associated upgrades at Long Spruce Station
- Four 27 km 230 kV transmission lines from Henday to Keewatinohk and associated upgrades at Henday Converter Station
- A 2000 MW converter station in the south (Riel Converter Station)
- Sectionalizing of the Ridgeway-Richer 230 kV line R49R into the Riel Converter Station, creating a Ridgeway-Riel 230 kV line M49R and a Riel-Richer 230 kV line M88R.



3.2 Bipole III Reliability Project (continued)

The 2000 MW converters will be designed with a 15% overload capability to provide spare capacity to cover the loss of a converter valve on the three bipole system.

Development of Bipole III will require a Class 3 license under The Environment Act (Manitoba). The environmental impact assessment for the project, including a program of community/public consultation and the identification of potential impacts and mitigative measures, has been documented in an Environmental Impact Statement (EIS). The project EIS was filed with Manitoba Conservation in the fall of 2011 as application for the Environment Act License. The Clean Environment Commission (CEC) began public hearings on Manitoba Hydro's Bipole III transmission project on October 1, 2012. The hearings provided participants with an opportunity to review and comment on the project and its environmental impacts. The hearings were completed in March 2013. An Environment Act License was received in August 2013. The target in service date for Bipole III is the summer of 2018.

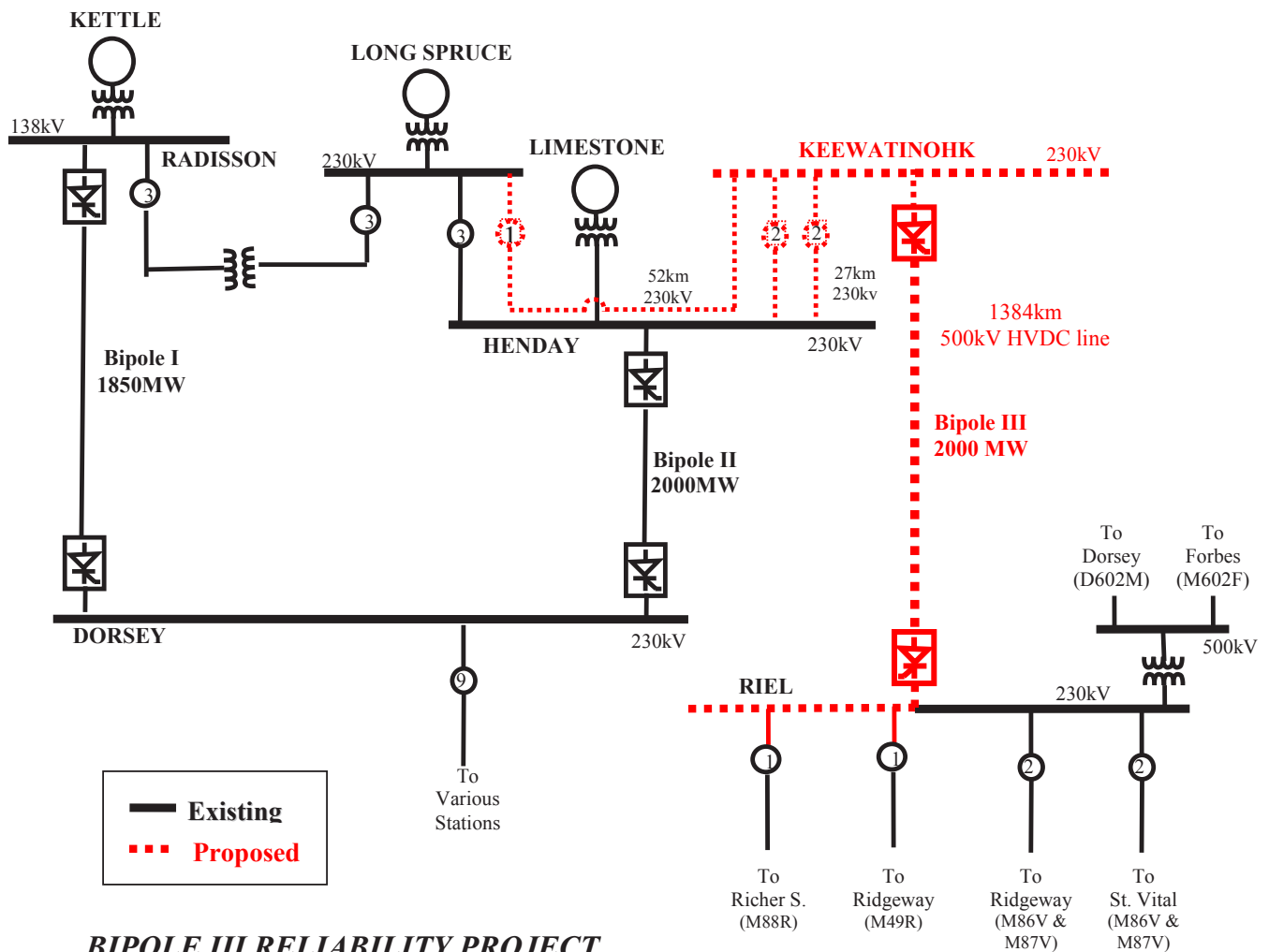

3.3 Transmission Line Refurbishments

Manitoba Hydro owns 183 transmission lines consisting of 85 - 115 kV, 26 - 138 kV, 69 - 230 kV, 1 - 500 kV line and 2 HVDC lines which total 11,350 km in length or 40,649 line spans. When transmission line conductors carry more current, they run hotter, expand, and sag closer to the ground. In an effort to ensure compliance with applicable transmission line clearance requirements, Manitoba Hydro has been implementing a Transmission Line Rating Verification and Mitigation Program since 1988. In 2000, the program began employing aerial surveys with LiDAR technology and advanced transmission modeling programs with approximately 500 km of transmission lines assessed per year. Since the beginning of the program, Manitoba Hydro has prioritized its assessment efforts based on the facilities with the greatest impact on the reliability of the bulk electric system.

The current status of the transmission line assessment program is summarized below:

- Spans assessed (rating status established): 35,639 (87.7%, 10,449 circuit kilometers)
- Spans requiring assessment (field survey required): 1,975 (4.9%, 510 circuit kilometers)
- Spans currently under assessment (2009 & 2011 LiDAR Program): 828 (2.0%, 148 circuit kilometers)
- Spans not included in scope of work due to future plans or remoteness of the transmission system: 2,207 (5.4%, 570 circuit kilometers)

A preliminary evaluation that has indicated that an estimated 1455 line spans at various voltage levels will require upgrades to mitigate deficiencies in their field ratings relative to their design ratings. The mitigation cost for these spans is estimated to be \$127 million (in 2013 \$) based upon historical work of similar scope.

The North American Electric Reliability Corporation (NERC) has become aware of discrepancies between the design ratings and actual field ratings of transmission lines. As a consequence, NERC issued an Alert on October 7, 2010 to the electrical industry with a recommendation that transmission owners conduct a field assessment of all transmission lines 100kV and above to determine the conductor clearances relative to the assumed design clearances and develop a plan to upgrade deficient lines. The Alert requires transmission owners to develop a three year plan describing how (LiDAR, manual surveys, etc.) and when field verification of the ratings of its unverified lines will be carried out for any lines whose ratings have not been verified by field measurement. Manitoba Hydro submitted a plan to assess the remaining 18% of the transmission system on January 18, 2011, NERC's deadline for these plans.

Manitoba Hydro's long standing Transmission Line Rating Verification and Mitigation Program has positioned Manitoba Hydro to respond to the NERC Alert. During the following nine years (2014 - 2022) Manitoba Hydro plans to upgrade the remaining deficient spans.

Future remediation work required as a result of assessments will be continued under the new transmission line upgrade NERC Alert program. This work was started in April 2014.

3.4 Lake Winnipeg East System Improvements

A new Manigotagan 115/66 kV station will eliminate the need for Pine Falls 66 kV system improvements. The new station will consist of two 36/48/60 MVA 115/66 kV transformers with on-load tap changers. A new 75 km long 115 kV line will be constructed from Pine Falls station to supply Manigotagan station.

Building a station at Manigotagan will reduce the need for further system improvements to support area voltage, and will allow for improved ability to serve area load growth. The new Manigotagan station will also reduce Pine Falls 66 kV station loading while allowing for Pine Falls station to serve local area load growth.

The in-service date is scheduled to be October 2016.

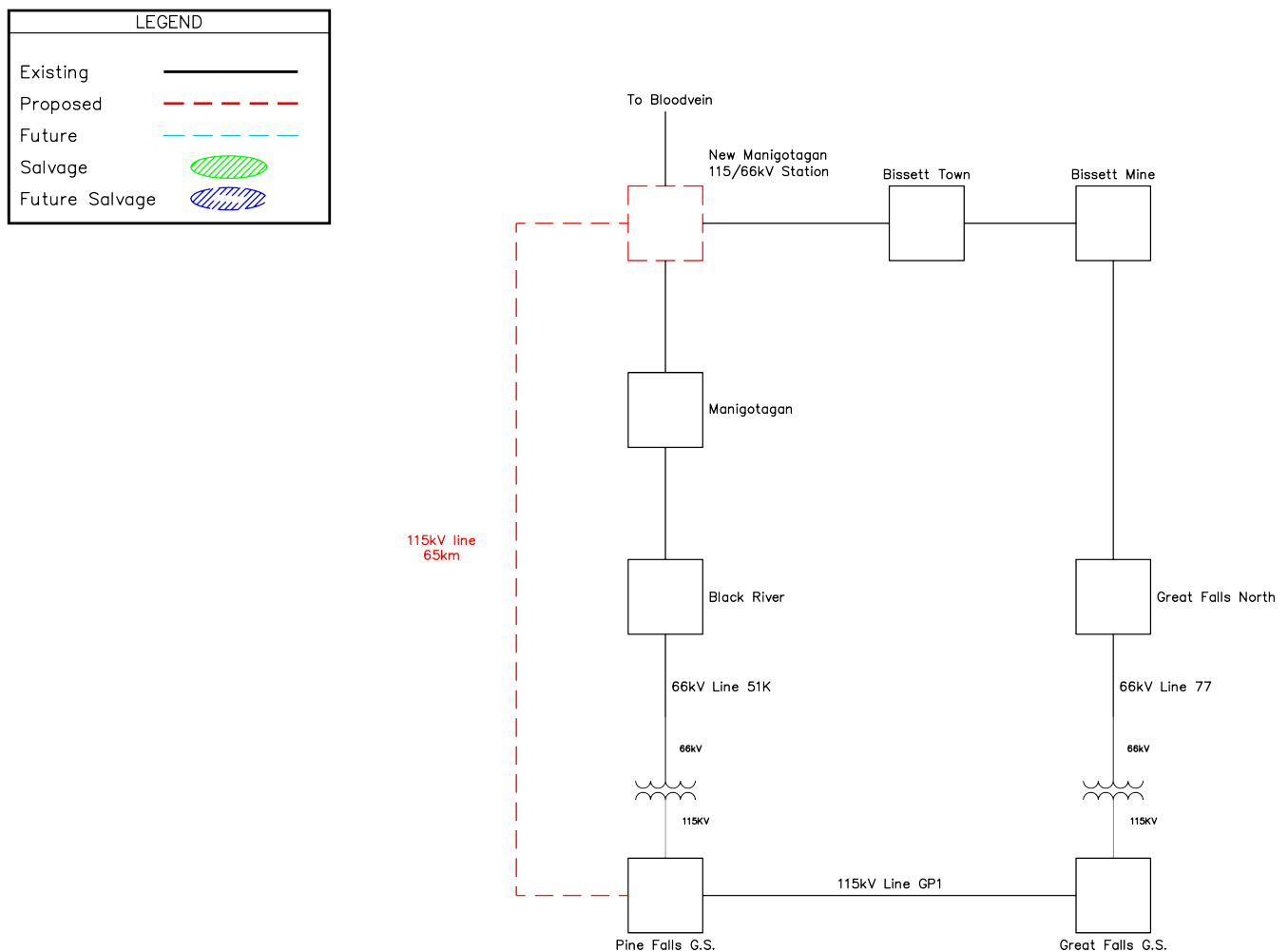

3.5 Rockwood East 230/115 kV Station

This project consists of the development of a new 230/115 kV Rockwood East Station supplied from sectionalized Ashern to Rosser 230 kV transmission line A3R.

The new 230/115 kV Rockwood East Station will be established in the vicinity (200m) of the 230 kV line A3R and S65R and approximately 11 km north of Rosser Station. A 230/115 kV 250 MVA transformer and associated structural and electrical apparatus will be needed to connect this new station to the existing 115 kV system. The proposed alternative is considered

superior to the other alternatives evaluated based on technical and economic analysis and successfully relieves transformer overloads at Rosser Station and overloads of 115 kV circuits CR4 or CR2 between Rosser and Parkdale Stations under contingency conditions.

The proposed in-service date of new 230/115 kV Rockwood Station is November 2015.

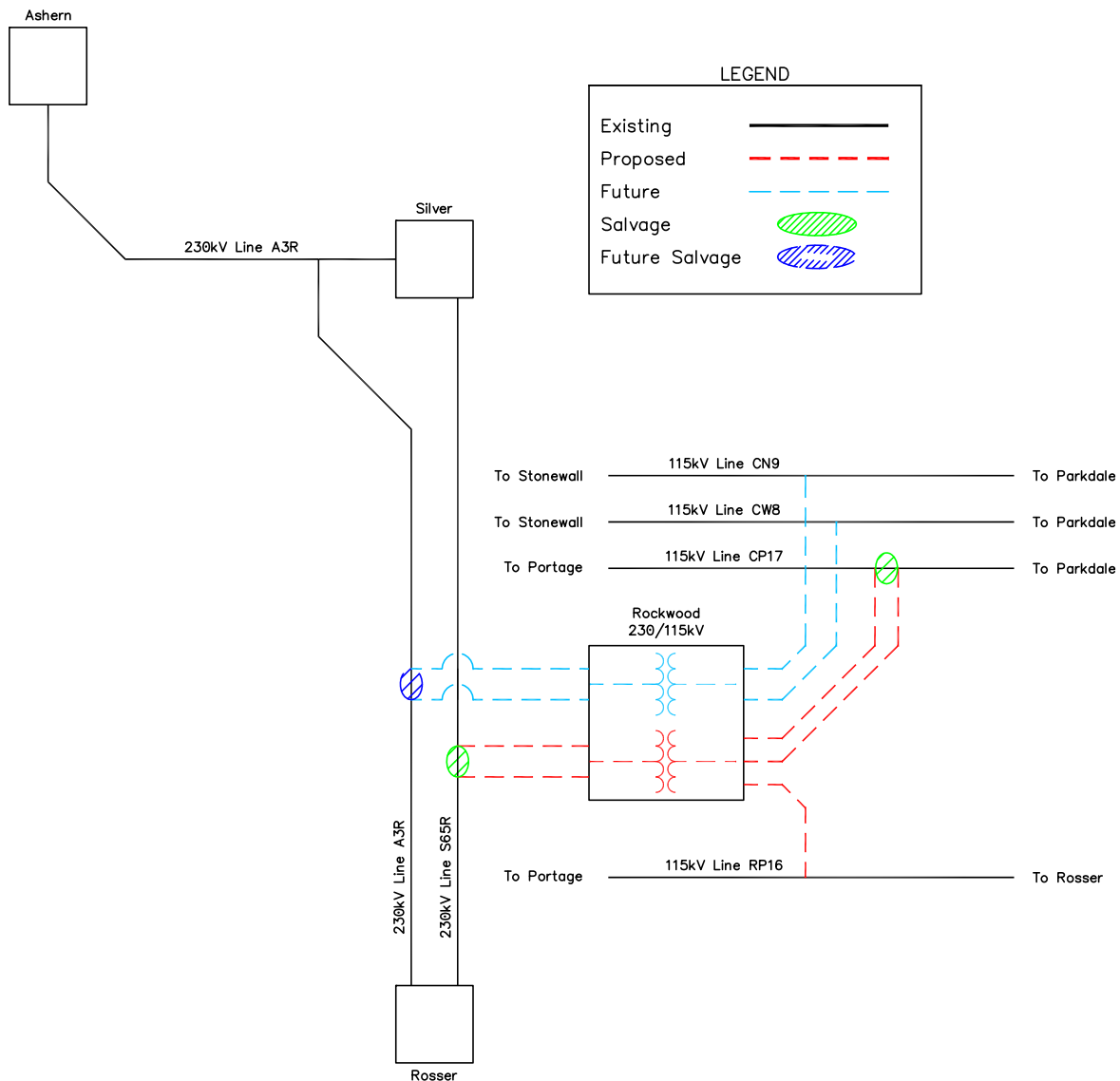

3.6 Winnipeg to Brandon System Improvements

Improvements to the Winnipeg to Brandon transmission system include the addition of three 10 MVAR, 66 kV capacitor banks at Portage South Station, and a fourth 54 MVAR, 115 kV capacitor bank at Brandon Generating Station. The project concludes with construction of a new Dorsey-Portage South 230 kV transmission line 70 km long.

Simulation studies using load growth forecast indicate that the loss of the Dorsey to Portage South (D12P) 230 kV line during the winter peak loading will cause voltage levels in the Portage South area to drop below acceptable limits within the next few years.

The Winnipeg to Brandon system improvements will provide the needed voltage support to increase system reliability and is one of several components required to remove the need to run generation at Brandon over the winter period.

In-service dates are as follows:

- Three 10 MVAR, 66 kV capacitor banks at Portage South Station were placed into service in 2009
- A fourth 54 MVAR, 115 kV capacitor bank was installed at Brandon Generating Station in November 2012
- Building a new Dorsey-Portage South 230 kV transmission line, 70 km long in April 2017.

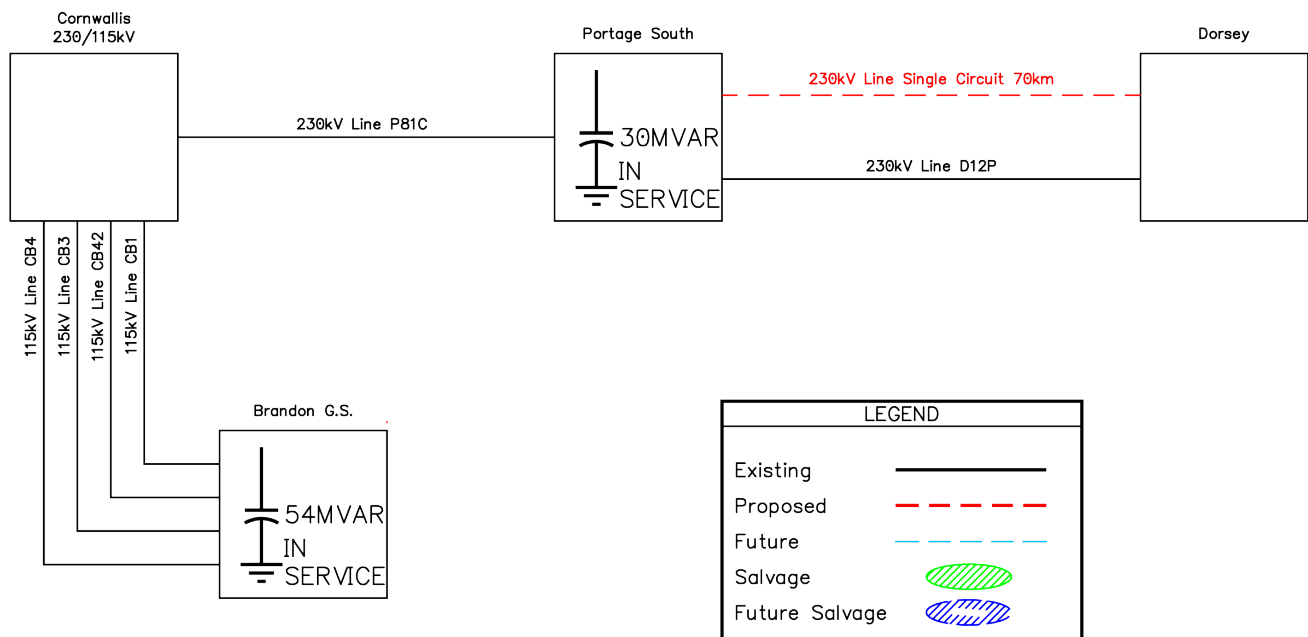

3.7 Stafford (Scotland) Station Rebuild

In order to provide additional capacity to the core Winnipeg area and facilitate the replacement of aging equipment at Scotland Station, the Scotland 138 kV and 115 kV - 66 kV Terminal Station is being rebuilt. This involves salvaging four 138-66 kV transformers, two 115-66 kV transformers, installing two new 125 MVA 115-66 kV phase shifter transformers and new 66 kV & 115 kV ring buses. The existing 80 MVA 115-69 kV phase shifting Bank 7 will be replaced with a new 125 MVA phase shifting transformer. The rebuilt station will be re-named Stafford. In addition, the 138 kV transmission system between Pointe du Bois, Slave Falls and Stafford (Scotland) are converted to 115 kV so that the former Winnipeg Hydro transmission can be integrated into the Manitoba Hydro 115 kV system. Pointe du Bois 138- 66 kV Bank 7 is replaced by a new 115-66 kV 60 MVA bank to accommodate the voltage conversion. Finally, the termination of lines YH33 and VS27 will be relocated from Harrow to the new Stafford station.

The station rebuild went into service in October 2014.

3.8 Neepawa 230/66 kV Station

A new Neepawa 230/66 kV Station is to be constructed near the existing Neepawa 115/66 kV station. The new station will include a 230 kV bus, a new 95 MVA, 230/66 kV transformer and a new 66 kV ring bus.

The new 66 kV ring bus will be connected to the existing 66 kV bus with a tie feeder. All 66 kV lines terminating at Neepawa will be re-terminated at the new 66 kV ring bus. The Dorsey-Cornwallis 230 kV line will be sectionalized into the new 230 kV bus to provide supply to the station.

Construction of the new station is driven by forecasted load growth in the area which causes unacceptable under voltage during contingency conditions.

The existing Neepawa 115/66 kV Bank 1 transformer will be utilized as a hot standby; during normal operation, its 66 kV circuit breaker will be open. This 66 kV circuit breaker can be closed when the new 230/66 kV transformer or the 66 kV tie feeder is out-of-service.

The scheduled in-service date is estimated to be March 2015.

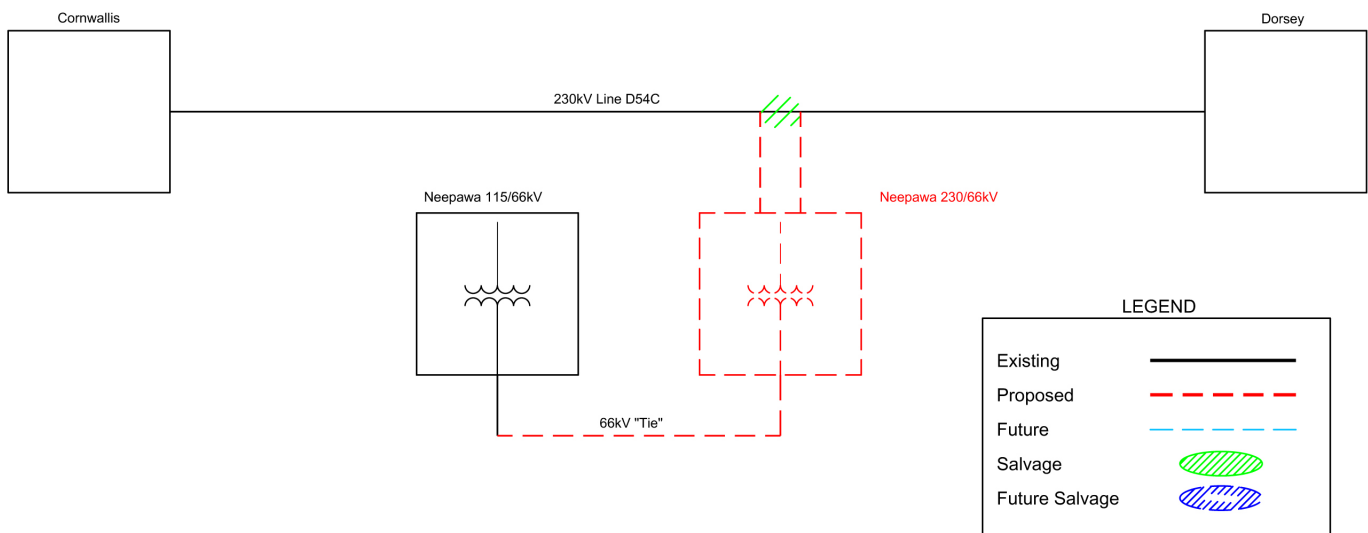

3.9 Stanley Station 230-66 kV Transformer Additions

Stanley Station requires the permanent installation of the hot standby transformer and a third transformer to ensure a reliable supply of electricity to meet growing demand in the Morden and Winkler area. This station, along with the 230 – 66kV station at Letellier, will ultimately supply the entire area of Stanley from the 230 kV network.

High load growth in the Morden and Winkler area required the installation of a second 230-66 kV transformer at Stanley station in 2010. Since the permanent installation of this transformer could not be completed at that time, a temporary solution was required. A 140 MVA transformer was delivered to the station and the transformer was installed as a hot standby with minimum installation.

The permanent installation of this hot standby transformer will include three new 230 kV breakers and two new 66 kV breakers. This phase of the project will also sectionalize 230 kV line S60L into Stanley.

To manage increasing area demand until such time as the hot standby can be made permanent, the functionality of the existing 93 MVA permanent transformer will be interchanged with the 140 MVA hot standby unit in fall of 2014. By reversing the roles of these banks and having the larger 140 MVA bank serving load, an interim solution is provided by increasing the load serving flexibility to the area. This will allow Stanley Station to pick up increased load off the 115 kV system.

A future 230-66 kV transformer, rated at 140 MVA, will be installed along with one new 230 kV breaker and two new 66 kV breakers. This installation will increase the firm station capacity at Stanley and provide the additional 66 kV transformation needed to supply the entire load currently supported by the 115-66 kV Morden Corner station. As previously stated, the entire 115 kV load presently served by Rosenfeld and Morden Corner Stations will ultimately be transferred onto the 230 kV network and supplied from Stanley and Letellier Stations by October 2016.

This re-supply of the Stanley area from the 115 kV to the 230 kV network will provide increased reliability to the area. This will allow for the future salvage of the 115 kV Morden Corner and Rosenfeld stations as well as the 115 kV lines YF11 and YM31.

To Summarize, the Stanley station expansion project has been divided into three phases:

Phase 1	Functional interchange of Existing and Hot Standby Transformers	I.S.D. October 2014
Phase 2	Permanent Installation of Hot Standby Transformer and Sectionalize Line S60L	I.S.D. October 2016
Phase 3	Installation of Third Transformer, Bus Upgrades and Salvage Work	Future

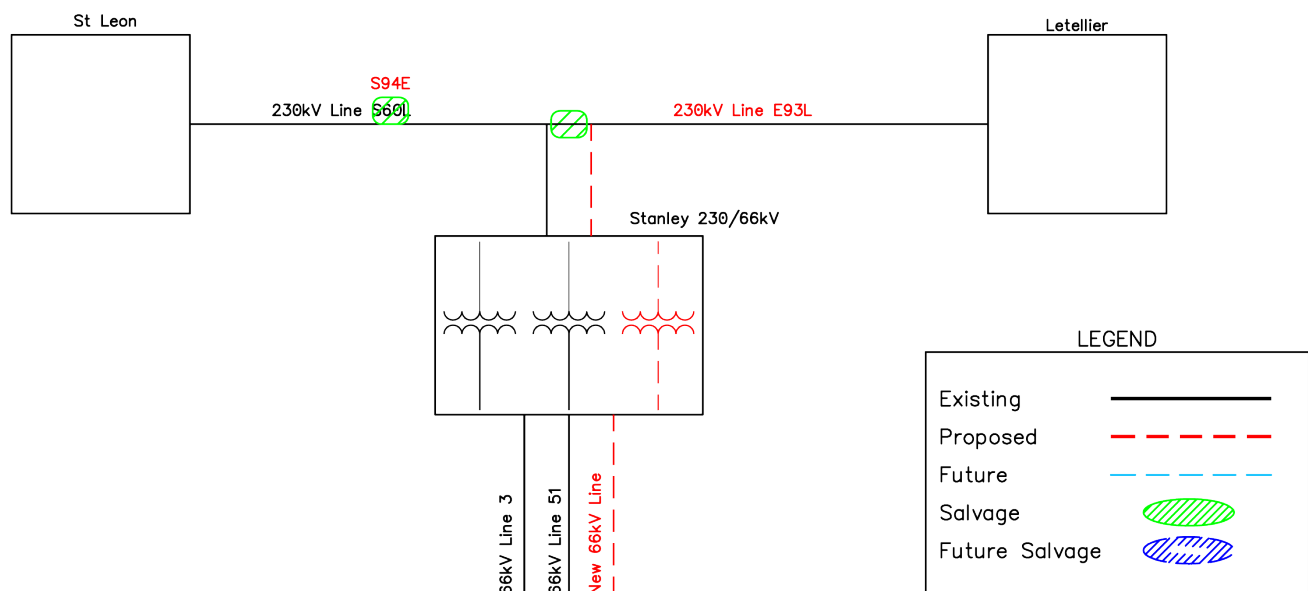

3.10 Pointe du Bois Transmission Line Replacement

The existing Pointe du Bois transmission lines consist of four transmission lines on two parallel sets of steel towers covering a distance of 124 km and operating at 66 kV. The lines were first installed in 1910 and have reached the end of their expected life and need to be replaced. The current plan is to salvage the existing Pointe lines and replace them with a new 115 kV line that will run from Pointe du Bois to Whiteshell Station.

Proposed transmission line from Pointe du Bois to Whiteshell station, along with existing Slave Falls to Stafford lines (as identified in Section 3.7) is planned to accommodate the existing generation capability of 76 MW at Pointe du Bois.

Several other system modifications are required to accommodate this including:

- Installing a new 66 kV line from Ridgeway to Rover including terminations at both stations.
- Salvaging two 115-66 kV banks at Transcona Station
- Installing a new 115-66 kV bank at Pointe du Bois

The salvage of P1 and P2 lines was completed in the spring of 2014, the in service date of the new 115 kV line and other modifications is spring of 2017 allowing for the salvage of the remaining P3 and P4 by December 2017.

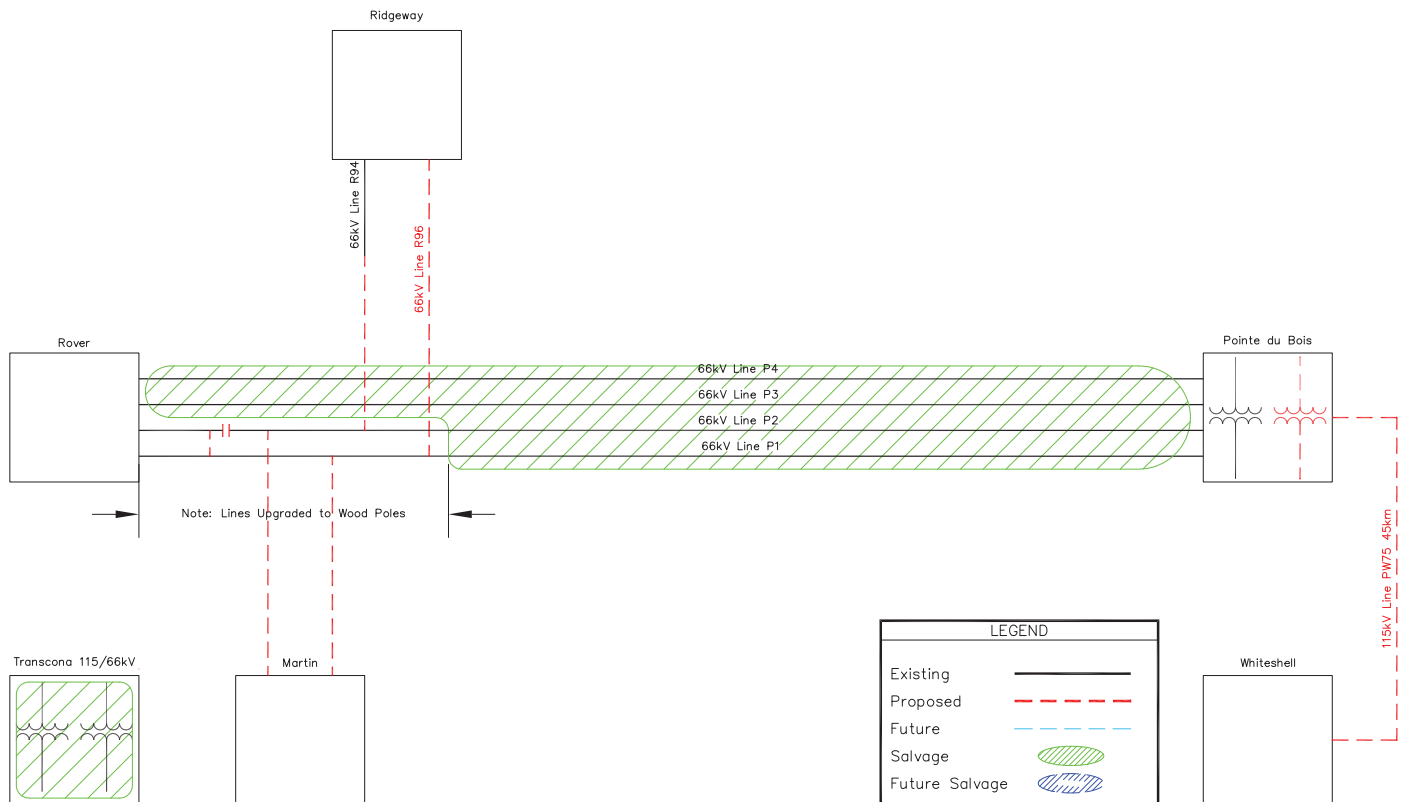

3.11 Improvements of 115 kV SW Winnipeg Transmission System

This project consists of the improvement and re-configuration of the south-west Winnipeg 115 kV transmission system required to meet performance criteria following various single and double contingency conditions. The project is divided into three stages.

The first stage consists of the rebuild of approximately 20 km of 115 kV line YS33 from La Verendrye to Stafford station as well as the upgrade of undersized line terminations at La Verendrye and Harrow.

It also involves the rebuild of approximately 14.5 km of 115 kV line VS27 from St. Vital to Stafford. The upgrade of undersized terminations at St. Vital will also be completed.

Stage two consists of opening 115 kV line YV5 creating a La Verendrye to Wilkes radial line, and terminating the former 115 kV line YV5 into Fort Garry Mohawk station creating a new St. Vital to Fort Garry Mohawk line.

The third stage includes the re-conductoring of 5 km of line VH1. The proposed alternative has been deemed to be superior based on technical and economic analysis of all alternatives considered.

The expected in service date of stage 1 is July 2016, stage 2 is December 2016, stage 2 is October 2017 and stage 3 is October 2022.

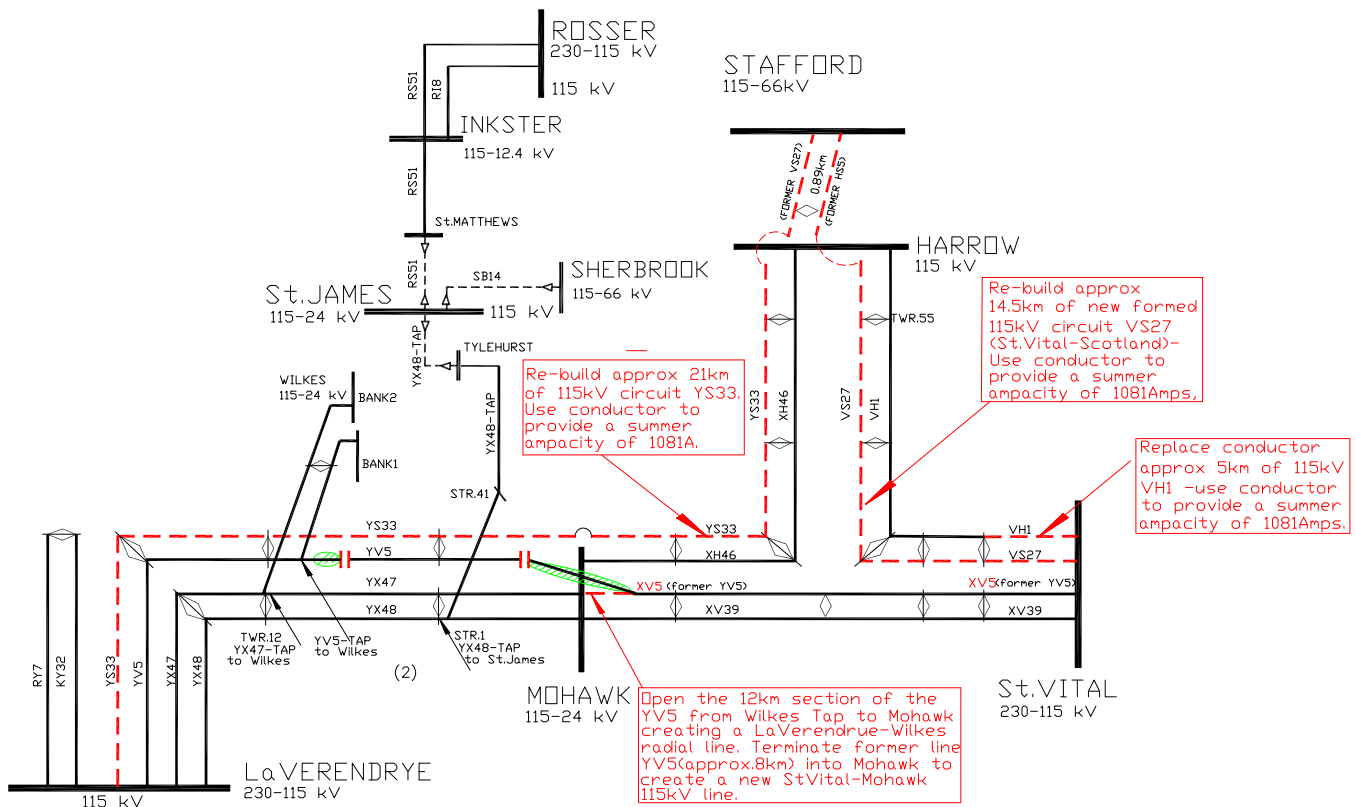

3.12 La Verendrye to St. Vital 230 kV Transmission Line

This project involves the construction of 37 kms of 230 kV transmission line between La Verendrye station and St. Vital station. The new line not only enables the 230 kV network in the Winnipeg area to withstand various severe outages, such as loss of Dorsey Converter Station, but also improves its performance during normal operation and promotes the reliability of the power system in southern Manitoba.

The Winnipeg area is the major load centre mainly supported by the 230 kV network partly around the periphery of the area which is presently fed by the Northern Collector System through Bipole I and Bipole II and will be supplied additionally by Bipole III. This 230 kV network is the heart of the major transmission network in southern Manitoba and its reliability poses a significant impact on the successful operation of Manitoba Hydro power system and the provincial

economy. Since the 230 kV network is not a 230 kV ring, it will be broken into segments and some stations will be isolated from the network during some severe outages, resulting in system operation difficulty or even a black out. The project will overcome these threats by upgrading the 230 kV network to a 230 kV ring by constructing a new 230 kV line between La Verendrye station and St. Vital station.

The proposed in-service date of the new 230 kV transmission line between La Verendrye and St. Vital is February 2018.

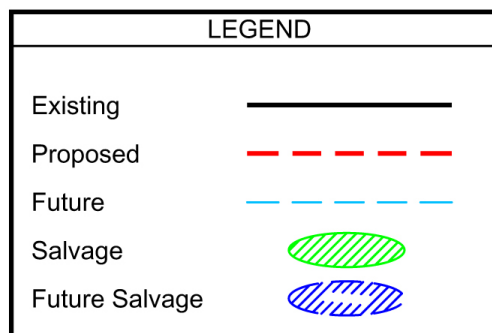

3.13 St. Vital to Letellier 230 kV Transmission Line

A new 125 km 230 kV line from Letellier Station to St. Vital Station is required to address contingency loading and low voltage concerns in the South Central area of Manitoba due to load growth in the area and to maintain export levels at these increased load levels.

Additionally, Lidar Survey analysis indicated that the extensive degradation of the rating of 115 kV line YF11 (La Verendrye - Rosenfeld) has occurred. The poor physical state of YF11 has a strong impact on the loading of 115 kV line YM31 (La Verendrye - Morden Corner/Rosenfeld). The addition of the proposed new Letellier - St. Vital 230 kV line would allow transferring the load from Rosenfeld and Morden Corner to the 230 kV-66 kV stations at Letellier, Stanley and the proposed Grunthal Station; a two 230-66 kV 140 MVA bank station (in-service date 2018). This would allow the retirement of YF11 and YM31 (not shown in the diagram) and eliminate the need for their refurbishment.

The scheduled in-service date is July 2017.

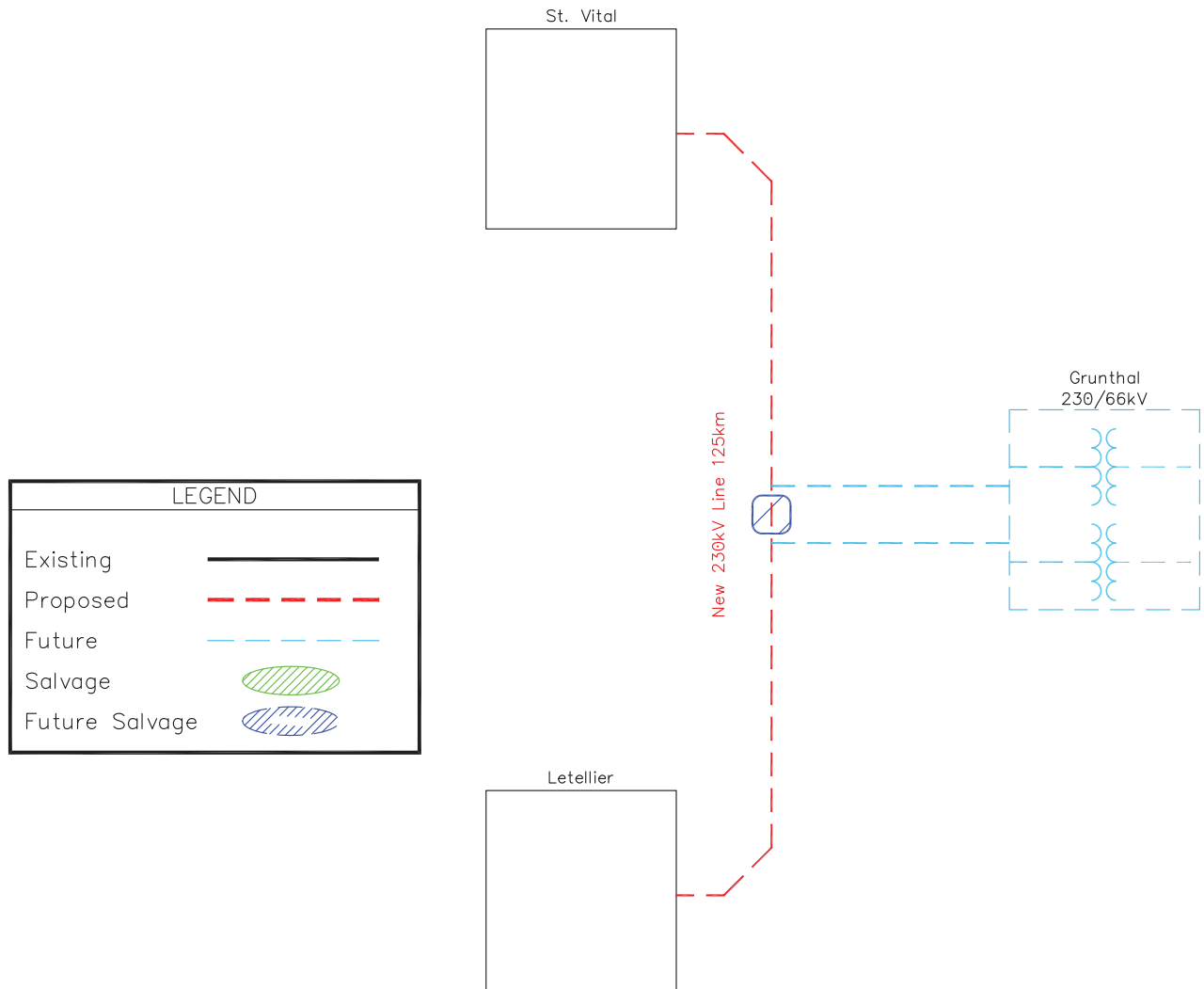

3.14 Keeyask Generation Outlet Transmission Facilities

The 695 MW Keeyask Generating Station (net 630 MW) consists of 7 units. New outlet transmission facilities are needed to connect the generating station to the Manitoba Hydro grid.

A new Keeyask Switching Station will be established to terminate seven new 138 kV lines including four unit lines (approximately 3 km each) to receive the power from Keeyask Generating Station, and three 138 kV transmission lines (approximately 38 km each) to convey the power to Manitoba Hydro's existing Radisson Converter Station. The 2000 MW Bipole III, slated to be in-service in 2017, will increase the capacity of the Bipole I, Bipole II and Bipole III HVDC to accommodate the Keeyask generation.

A construction power station will be built and fed primarily from a 138 kV transmission line with an approximate length of 22 km tapped from existing line KN36. One of the Radisson-Keeyask lines will be constructed earlier than the other two, in order to serve

as a back-up source of construction power. Station upgrades at the Radisson station will also be required. In addition to connecting new generation to the system, the new facilities will improve the reliability of the overall transmission system.

The in-service date for the first unit at Keeyask is November 2019. All of the transmission facilities will be completed by September 2019.

Keeyask transmission is being constructed pursuant to the terms of the Open Access Interconnection Tariff (OAIT), and plans for construction will start only after the Keeyask LP signs an Interconnection and Operating Agreement (IOA).

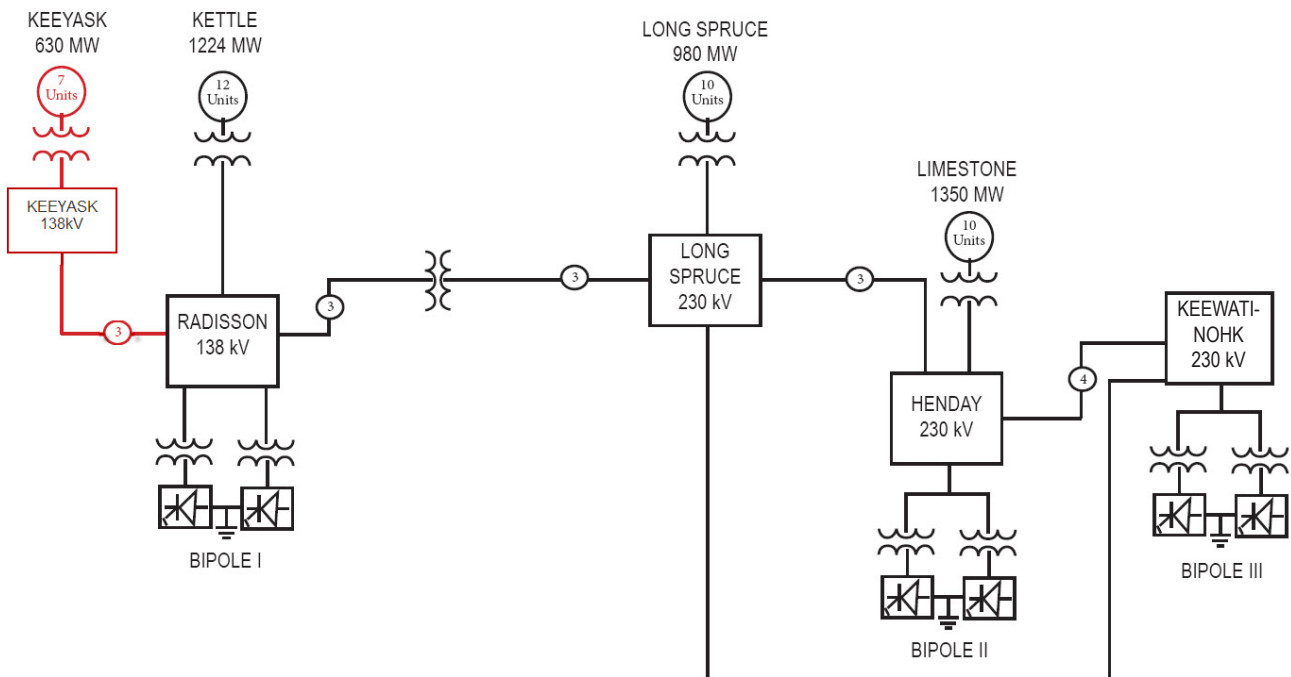
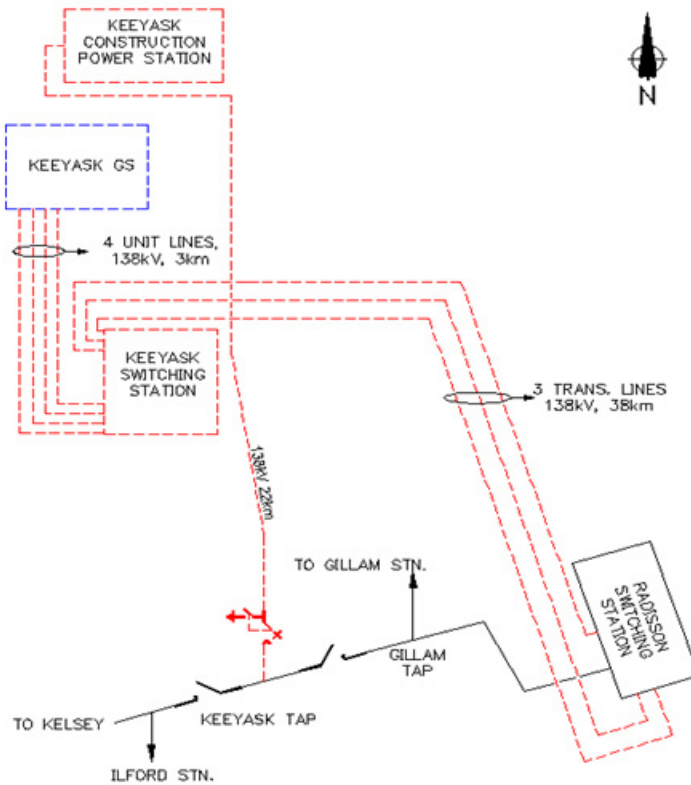

4. Future Capital Requirements for Transmission

Traditional system planning challenges have primarily been related to a mandate to deliver electricity to load centers in a reliable and cost-effective manner. The development of electricity markets has provided additional challenges associated with the requirements to provide non-discriminatory generator interconnection and transmission service.

4.1 Planning Process

Manitoba Hydro's transmission planning process identifies plans to connect new generating resources and new customers and assesses the adequacy of the existing and planned transmission network to provide a reliable and economic supply of electricity to Manitoba customers and export customers. Conceptual plans are developed, based on generation and load forecasts over a 10 year period, to ensure that the Manitoba load and contractual firm exports can be served.

Manitoba Hydro plans transmission facilities in compliance with all applicable local, regional and international reliability standards and requirements. Planning studies and assessments follow methodologies and must meet standards and criteria established by Manitoba Hydro and other regional entities such as the Midwest Reliability Organization (MRO) and NERC.

Manitoba Hydro expects its transmission system to meet performance requirements set out in the NERC Planning Standards. The NERC Planning Standards require a transmission system performs in a reliable manner not only under normal system operating conditions but also following a range of system disturbances. As a member of the MRO, Manitoba Hydro complies with the NERC Planning Standards by completing a Ten-Year Resource Adequacy and Transmission Reliability Assessment Study annually and submitting a study report and documentation of any planned transmission system upgrades to the Midwest Reliability Organization.

The NERC 2013 Transmission Planning Assessment for Manitoba demonstrated the existing and planned transmission system over the next ten years can operate at all load levels and expected firm transfer conditions while respecting unscheduled contingencies and meeting the NERC performance requirements.

Overloads of Pointe du Bois – Stafford (Scotland) 115 kV Lines (S1 and S2) occur under 2018 and 2023 summer operating conditions. Loss of one of these parallel lines results in overload of the other line and loss of the proposed Pointe du Bois to Whiteshell

115 kV Line (PW75) also causes overload of S1 and S2 lines. S1 and S2 lines have recently been given a 30 minute emergency overload capability of 115% (342 amps).

The loss of Brandon G.S. to Crocus Plains station 115 kV Line (BD52), causes Brandon Victoria to Brandon Highland Park 110 kV Line (EH13) to be overloaded slightly under 2023 summer peak operating conditions. A 2 km section of EH13 line is comprised of a smaller conductor (266.8 26/7 ACSR - 75 °C),if this section is re-tensioned to 100 °C, the overload is eliminated. Future load growth may or may not be as high as forecasted, therefore, this line loading will be monitored and appropriate fixes will be recommended when and if it occurs.

Two post-contingency voltage violations due to loss of Lavarendrye to Rosenfeld 115 kV Line (YF11) at Morden and Rosenfeld 110 kV buses were observed in the present year winter peak cases. Transferring Altona load from Rosenfeld Station to Letellier Station helps to improve the current voltage issues. An appropriate operating procedure is being developed as an interim solution for the planning years of 2014 and 2015. Additional infrastructure development with an ISD of October 2016 is planned for providing a long term solution for these voltage issues (Stanley Station 230/66 kV Transformer Addition).

Transmission alternative plans are developed in consultation with stakeholders and assessed on various factors including cost, feasibility to implement, lead-time to construct, and impacts on the environment.

A preferred transmission solution is selected based on the above analysis of the conceptual plans.

Public consultation and regulatory approvals are normally required, depending on the type of system modifications proposed, to implement the selected plan. Manitoba Hydro follows a Site Selection and Environmental Assessment process which includes public consultations, to select locations for stations and routes from transmission lines and obtain the regulatory licenses necessary for construction of new facilities.

Once all approvals and corporate funding are in place, detailed engineering, material procurement, construction and commissioning take place. The project implementation phase for new facilities can take several months to several years, depending on the scope and complexity of the project.

The Manitoba Hydro transmission plans are reviewed annually to reflect changing circumstances such as changes in customer demand, the need for reliability enhancements, or the addition of new generator connections. As a result of this review, some projects may be advanced, deferred, deleted or replaced with a new project which takes advantage of new technology, while many of the projects will be retained as proposed.

4.2 Future Transmission Interconnections

As detailed in Appendix 1, the transmission system in Manitoba is interconnected to the transmission systems in the provinces of Saskatchewan and Ontario and the states of North Dakota and Minnesota by 12 tie lines. Of these, three 230 kV lines and one 500 kV line interconnect the Manitoba system to the United States, three 230 kV and two 115 kV lines interconnect to Saskatchewan, and two 230 kV lines and one 115 kV line interconnect to Ontario.

These interconnections allow for economic exchange of electricity as well as provide support during electric system emergencies. The interconnections are especially beneficial to Manitoba due to the characteristics of Manitoba Hydro's predominantly hydraulic generation system. As well as exporting electricity surplus to Manitoba's needs the interconnections allow Manitoba Hydro to import energy when economic or when river flows are low. Planned upgrades are developed to mitigate any performance deficiencies identified in the annual assessment. The past development of its hydroelectric generating plants on the Nelson River in northern Manitoba has allowed Manitobans to enjoy some of the lowest electricity rates in North America. Manitoba Hydro is exploring the feasibility of developing new northern hydroelectric generation sites to meet future domestic load growth. New interconnections and new contracts are also evaluated to export surplus energy.

Manitoba Hydro has a firm contract with Minnesota Power (MP) to provide 250 MW over 15 years starting in 2020 and a firm sale of 108 MW to Wisconsin Public Service (WPS). Manitoba Hydro has also signed a sale contract with WPS to provide up to additional 308 MW over 15 years starting in 2027. The proposed power sales agreements will facilitate new hydroelectric development in northern Manitoba (Keeyask and possibly Conawapa) and a new transmission line between Canada and the United States. Studies are underway with the Midcontinent Independent Transmission System Operator (MISO) to determine the necessary transmission facilities needed to increase the firm Canada to U.S. transmission export and import capability.

This project could have the following components:

1. Development of a 500 kV AC Transmission Tie Line from Dorsey-USA border. The 500 kV AC transmission link to connect Dorsey Station to the U.S. border is expected to be located within the south loop corridor that currently is located to the south of Winnipeg.
2. Dorsey-Blackberry (a station in Iron Range, north eastern Minnesota) 500 kV AC Transmission Line.
3. Addition of a second 500/230 kV transformer bank at Riel Station.
4. Addition of a phase shifting transformer at Glenboro 230 kV Station on Glenboro – Rugby (US) 230 kV Line (G82R). This device is being added to mitigate loop flow issues on the Manitoba to US interface.

Modifications to Dorsey will consist of equipment additions and modifications required to terminate the 500 kV transmission facilities.

The expected in-service date of the plan is May 2020 and the project which is being pursued through Open Access Transmission Tariff (OATT), was recently reviewed and approved as part of the Need for and Alternatives to process.

4.3 Access to Electricity Markets - Transmission Service

Manitoba Hydro offers access to its transmission system in accordance with its Open Access Transmission Tariff (OATT). The OATT has added new challenges, as Manitoba Hydro transmission planners must respond to requests from transmission customers to use the transmission system for market transactions into, out of, or across Manitoba, and for delivery of generator output to load. To respond to a request for transmission service, planners must assess the capability of the existing infrastructure to accommodate the transaction. If the existing system cannot accommodate the desired transaction, plans for system upgrades are developed. The cost of construction of system upgrades required to accommodate a transmission service request are the responsibility of the transmission customer. Requests for transmission service are processed in the order in which they are received.

The details of the OATT and the Transmission Service request process can be found on the Manitoba Hydro OASIS website, which can be found at the Manitoba Hydro website (<http://www.hydro.mb.ca>), then

by clicking on Transmission Tariffs for Energy for Suppliers and Power Producers, under Your Business tab, and then selecting either the Transmission Tariff Link or Interconnection Tariff Link to get to the Manitoba Hydro OASIS page. (<http://www.oasis.oati.com/MHEB/index.htm>) OATT and Transmission Service request can be found under open Access Transmission Tariff heading.

4.3.1 Ontario Interface Transmission Services

Studies have been completed in identifying facilities to maintain the current Manitoba to Ontario export capability of 200 MW and increase Ontario to Manitoba import capability up to 100 MW. It was found that no new transmission is required and only upgrades to existing transmission lines such as Whiteshell-Transcona (WT34) re-conductoring and station facilities are needed. Studies to determine the required in-service date for WT34 upgrades are on-going.

4.3.2 Saskatchewan Interface Transmission Services

Studies are ongoing to address Transmission Service Request facilities to increase the Manitoba to Saskatchewan export capability up to 150 MW and Saskatchewan to Manitoba import capability up to 100 MW. A new 100 km long 230 kV tie line between Birtle South (Manitoba) and Tantallon (Saskatchewan) Stations and minor upgrades to existing transmission lines and station facilities would be required.

4.4 Future Generation Interconnection

As stated earlier, one driver of transmission development is generator connection. Historically, Manitoba Hydro has been the sole generation developer in Manitoba, with the exception of some “behind the meter” generation in major customer plants. An integrated resource/transmission planning process was used to connect new generation to the transmission system.

The development of electricity markets in North America has changed the process for connection of generators in Manitoba. Transmission providers are required to connect non-utility generators to the system as part of the requirement to participate in the market. Generation interconnection service is to be provided on a non-discriminatory basis, comparable to that provided to Manitoba Hydro’s own generators. To meet this requirement, Manitoba Hydro has developed an Open Access Interconnection

Tariff (OAIT), which provides for connection of all generators to Manitoba Hydro’s transmission system. Manitoba Hydro provides this interconnection service to all generators requesting connection in Manitoba on a “first come, first served” basis.

On receipt of a valid generation interconnection request, interconnection studies are conducted to evaluate the system impacts associated with the new generator and the facilities required to interconnect the generator. The cost of transmission facilities and network upgrades required to connect the new generator are the responsibility of the generator.

For details on procedures used to request connection to Manitoba Hydro’s transmission system and the technical requirements for such connections, refer to Manitoba Hydro’s Open Access Interconnection Tariff. This document is posted on the Manitoba Hydro OASIS website, which can be found on the Manitoba Hydro website (<http://www.hydro.mb.ca>), by clicking on Transmission Tariffs for Energy Suppliers and Power Producers, under Your Business tab, and then selecting either the Transmission Tariff link or Interconnection Tariff link to get to the Manitoba Hydro OASIS page. (<http://www.oasis.oati.com/MHEB/index.htm>)

Complete generation queue can be obtained from the above link by clicking on Generation Queue under Open Access Interconnection Tariff.

Wuskwatim Generating Station in northern Manitoba and the new wind generating station at St. Joseph were processed in accordance with the terms and conditions of the OAIT.

As it was described in section 4.2, proposed export sales to Wisconsin Public Service & Minnesota Power, will require new hydraulic development in northern Manitoba namely Keeyask (695 MW). Transmission for Keeyask is described in Section 3.14.

4.5 Wind Generation Interconnection

Manitoba Hydro completed exploratory wind studies to rank a set of twenty-three potential wind farm interconnection locations and determine a list of top ten desirable interconnection locations for wind generation in Manitoba. The study divided the province into zones and determined the required transmission facilities and network upgrades required to reliably connect up to 300 MW of wind generation in each zone. Each potential interconnection location was then ranked based on the cost and feasibility of the transmission facilities and network upgrade requirements associated with the interconnection.

As a result of request for proposals (RFP) for the purchase of up to 300 MW of wind energy issued by Manitoba Hydro a 138 MW wind farm consisting of 60, 2.3 MW Siemens wind turbines was connected at St. Joseph in the spring of 2011. Transmission Planning has completed the Interconnection Facilities study for the St. Joseph wind farm and determined the interconnection upgrades and network system upgrades. Interconnection upgrades included a new 5 km 230 kV line from the Letellier substation to the St. Joseph wind substation, Letellier substation upgrades and protection system upgrades/additions.

Network System upgrades required re-conductoring L20D and G37C. The L20D re-conductoring has been completed. Re-conductoring of G37C was recently completed in November 2011 and consisted of resagging and replacing some transmission poles to improve clearances.

An exploratory study to connect up to 1200 MW of wind generation to the Manitoba Hydro system has been completed. A resource adequacy assessment was also performed. 230 kV and 500 kV transmission expansion plans were developed for the wind installations. The short circuit level is found to be strong enough that no transient or voltage instability problems are evident. Some small signal oscillations are noted with Type-3 wind turbines when a two-mass model is used which aren't present with a Type-4 turbine. The need for wind inertia was assessed. The addition of 1200 MW of wind degraded the transient frequency response but did not violate underfrequency criteria; therefore special inertia controls are not required at this level of wind penetration.

Three 230 kV plans and one 500 kV plan were chosen as the best options for further evaluation in the transient stability domain. High level diagrams of one of the 230 kV and 500 kV transmission plans are shown in the figure on the next page.

In the 230 kV plans, the wind plants were collected into two stations, with each station having at least three 230 kV outlet lines. In the plan shown in the figure below, an existing station (known as Stanley) was assumed to be expanded to accommodate the wind generation. The 230 kV plans required around 200-230 km of new network transmission, not including the 230 kV transmission needed to connect the wind collector sites to the Points of Interconnection (POI), which required an additional 135 km of 230 kV transmission.

In order to compare with a 500 kV solution, a single radial 500 kV line from the wind plants to the major load centre near Winnipeg was also assessed. The length of this 500 kV line was around 130 km. In this plan, the wind plants were collected into one 230 kV station, and were stepped up to 500 kV. Approximately 150 km of 230 kV transmission was needed to connect the new 230 kV station to the wind collector sites.

The ultimate plan will be dependent on the actual location and size of specific wind plants. A 230 kV transmission plan was found to be superior to a 500 kV plan for 1200 MW as the plan was lower in cost, more reliable and more energy efficient.

An additional 16 MW (10-1.6 MW wind turbines) of wind capacity has been added at St. Leon to the existing wind farm in 2012.

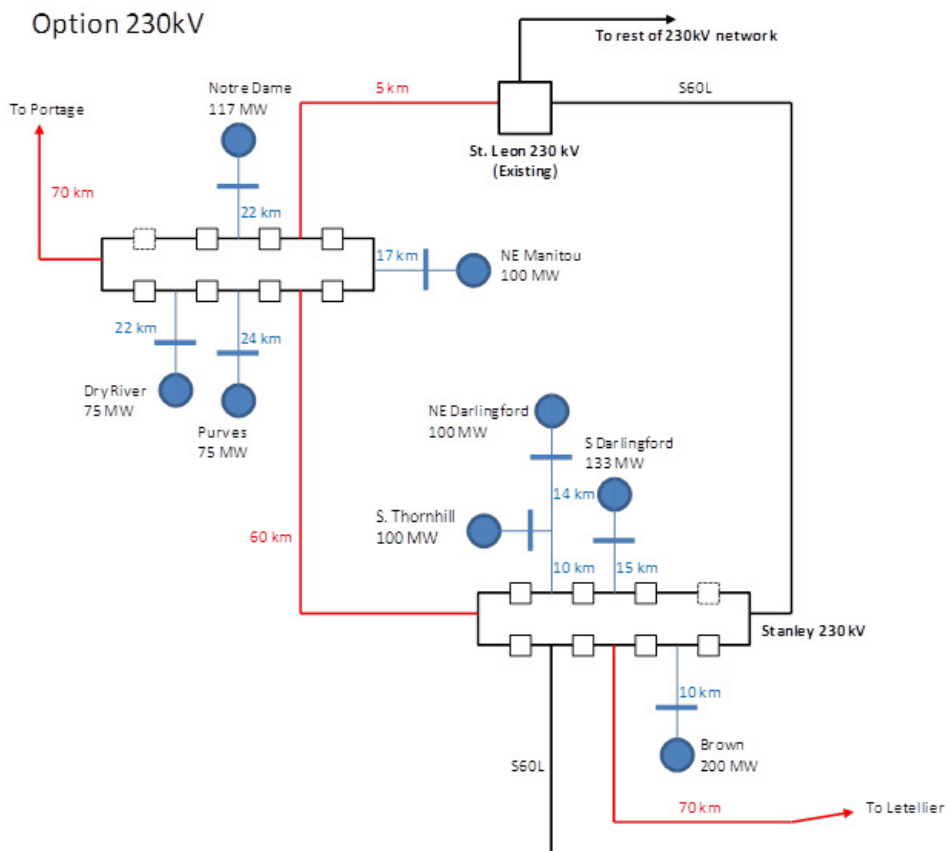
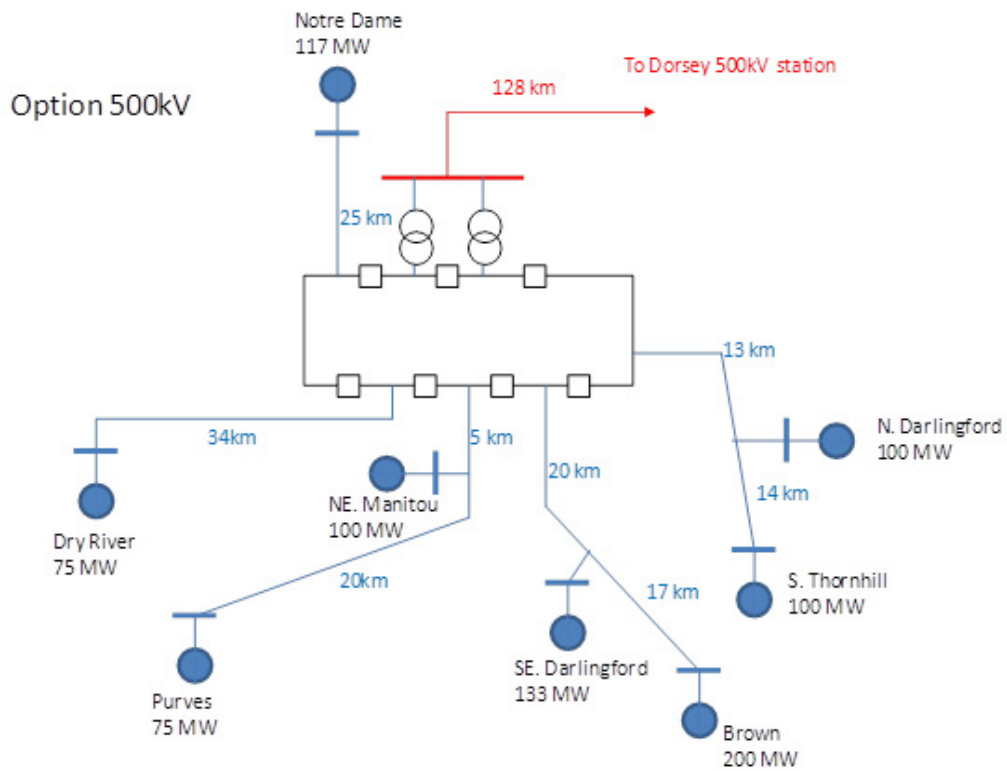

4.6 Northern Exploratory Study

A recent Exploratory Study examined the reliability limitations with up to an additional 400 MW of firm hydro generation connected to the northern AC system. The objective of the study is to determine transmission solution(s) and associated cost estimates to connect up to 400 MW of generation to the Radisson 138 kV bus, with minimal impacts to Manitoba Hydro-Sask Power (MH-SP) loopflow and MH system losses. The upgrades and cost estimates will be identified for generation amounts of 100 MW, 200 MW, 300 MW and 400 MW. Each case also includes an additional 85 MW of firm generation from Wuskwatim (23 MW) and Kelsey (62 MW).

Based on overall connection cost estimates that take into account energy loss savings over a 30 year period, the 500 kV AC transmission solutions are the preferred alternative when compared to the 230 kV transmission solutions for connecting 400 MW or more of new generation to the northern AC system. The 500 kV options also provide some added flexibility for connecting future generation beyond 400 MW as the incremental costs to connect more generation would be lower than if a 230 kV solution were implemented. It should be noted however that as more generation would be added to make use of the 500 kV AC transmission, more generation unit tripping would be required to maintain transient stability for loss of a section of the 500 kV transmission line, or if unit tripping were not used then more upgrades would be required on the underlying 230 kV system.

The study also demonstrated that 230 kV northern AC system with appropriate upgrades could deliver up to 300 MW at less cost than the 500 kV line.

The exploratory study has been used to help define the transmission plan for Conawapa.

4.7 Major Customer Interconnection and Load Addition

Manitoba Hydro has developed a process to connect new loads or load increases of large customers. A Load Interconnection Evaluation Study (LIES) is conducted to identify the impact of the new load on the system, the preliminary costs of direct connection facilities and system upgrades, including a preliminary timeline for construction. Studies are based on high level information provided by the customer on the nature of the load. The LIES provides information to allow the customer to decide whether or not to proceed with the interconnection. If the Customer decides to proceed, a detailed Load Interconnection Facility Study (LIFS) is completed. This study provides cost estimates and timelines required to connect the new

load or accommodate the load increase. It is based on detail provided by the customer on the expected load characteristics. These studies lead to various agreements for construction and supply being signed.

Vale Inco, located at Thompson has announced the closure of its smelter and refinery in 2015 due to reduced ore supply and environmental compliance challenges. The closure will result in reduction of the existing 155 MVA of electrical demand to 50 – 60 MVA.

In September 2013, HBMS Lalor station was placed into service with a potential load of 35 MVA.

Manitoba Hydro has approximately 200 MW of new load connection requests from a number of customers in process that may appear on the system within the next five years.

4.8 Addressing Aging Infrastructure

Starting in 2009, Manitoba Hydro's Transmission Business Unit began an initiative to assess the risks associated with its aging transmission system infrastructure and to establish long term plans and budgets to manage these risks.

The initiative started by reviewing asset age demographics and current approaches to asset management, and by identifying three critical assets types that were thought to have the largest impact on reliability, capital budgets, and operating and maintenance budgets: The assets were substation transformers, circuit breakers, and transmission lines.

In 2012, the Transmission Business Unit employed a consultant to help develop asset condition assessment methodologies for these three asset types. Manitoba Hydro provided the consultant with its available asset data (e.g. age demographics, test data, inspection data, maintenance history, utilization data, etc.) and expertise on the assets under consideration. With this information the consultant developed methodologies to assess the condition of the transmission system's transformer, circuit breaker, and wood pole transmission line structure assets.

Based on these initial condition assessment results and associated forecasts provided by the consultant, Transmission has established three long-term sustainment capital programs as part of our capital plan to fund proactive replacements and refurbishments and to manage the risks associated with aging infrastructure:

- Transformer Sustainment Capital Program
- Circuit Breaker Sustainment Capital Program
- Transmission Line Wood Pole Structure Sustainment Capital Program

4.8 Addressing Aging Infrastructure (continued)

More recently, Transmission has continued to expand its condition assessment program to include other asset types such as transmission line conductors and steel towers, station batteries and protection relays. This type of information will be used by Transmission going forward to develop investment plans to manage the risks resulting from the impacts of aging infrastructure.

4.9 Northern Damping (Low Frequency Oscillations)

The power system consists of generators interconnected by transmission lines. Under some operating conditions, such as after faults, power swings (Low Frequency Oscillations) can occur between generators. These power swings are not problematic as long as they are well damped. Power systems stabilizers applied to generators, SVCs and HVdc controls ensure sufficient damping for both local and inter-area power swings. Damping criterion for power system oscillations is specified in the Manitoba Hydro Transmission System Interconnection Requirements.

The recommended improvements to the generator controls at Kelsey have been implemented and the project was completed in 2013. Similar upgrades, scheduled to begin in 2012 and to be completed by 2015, have also been approved for Grand Rapids. These changes will help to ensure that sufficient damping is provided for power swings.

Several Phasor Measurement Units (PMUs) have recently been installed, which will allow Manitoba Hydro to have a real-time wide area view of its power system to help identify and mitigate potential causes of instabilities in its electric grid before they develop into significant disturbances and possible failures. This technology was used to verify settings of existing power system stabilizers as well as future planned additions. This tool was used to commission the power system stabilizer on the 165 MVAR static var compensator at Birchtree. The tool allowed for rapid confirmation of setting performance as well as assurance of no adverse interaction between the various plants.

4.10 Future Transmission Corridors



Manitoba Hydro currently has in excess of 4000 MW generation capacity developed in northern Manitoba. A small segment of this power is consumed in northern Manitoba, but the majority is transmitted to load centers and export markets in the south. The potential exists for many more thousands of MW of new hydraulic generation in the north, with much of that power likely to be required in the south.

Three transmission corridors are currently available between northern and southern Manitoba; a corridor west of Lakes Manitoba and Winnipegosis, a corridor through the Interlake region, and an eastern corridor using a combination of overhead line, underground cable and underwater cable beneath Lake Winnipeg (see figure left). This latter corridor, proposed recently by Concepts Review Panel, is described in detail in a report titled “Potential Use of Submarine or Underground cables for Long Distance Electricity Transmission in Manitoba – A Post Bipole III Concepts Review” (<http://electricalline.com/node/2299> or http://www.hydro.mb.ca/corporate/research_and_development/post_bipoleIII_concepts_review.pdf)

To date, as generation was developed, there has been extensive use of the Interlake corridor. As new generation is developed, routing decisions within these three corridors will be required to effectively

deliver new power to southern Manitoba, while respecting risks inherent with concentration of power within a single corridor.

The process for selection of a route for Bipole III was evaluating a western route corridor in order to achieve separation from Bipole I and Bipole II Interlake corridor.

With the establishment of Riel Station in the southeastern periphery of the City of Winnipeg, there is a need to complete a loop of transmission corridor around the city. The northern portion of this loop corridor has been established for some time and the existing 500 kV line from Dorsey to Forbes uses this corridor already as well as several 230 kV lines between Dorsey, Rosser, Ridgeway and St. Vital.

The possible future development around the city of Winnipeg of the south loop corridor from Dorsey to Riel could include up to two 500 kV transmission circuit. This corridor would also include up to three 230 kV transmission lines from St. Vital (or Riel) to La Verendrye. Another possibility for 230 kV transmission in this corridor is to connect new generation to Riel, St. Vital or La Verendrye stations (see figure on next page).

4.11 Resource Adequacy

Demands for highly reliable electric power have increased tremendously in the past few decades. It is expected that the requirement for reliable power supply will continue to increase in the future especially in today's changing environment. The reliable supply of electric services depends on adequate and dependable generation and transmission facilities. Over the years, deterministic criteria were used in virtually all practical power system applications to determine the system adequacy levels and some of them are still in use today. The essential weakness of deterministic criteria is that they do not respond to the random nature of component failures, customer demands and system behaviour. Since a power system behaves stochastically, probabilistic methods should be used in power system planning to determine the amount of resources and corresponding transmission to ensure an acceptable level of service reliability. Manitoba Hydro uses a probabilistic adequacy criterion of 0.1 day/year or 1 day in 10 year loss of load expectation (LOLE) in resource adequacy planning. This LOLE reliability level is currently industrially accepted. Compliance with this criterion is evaluated annually.

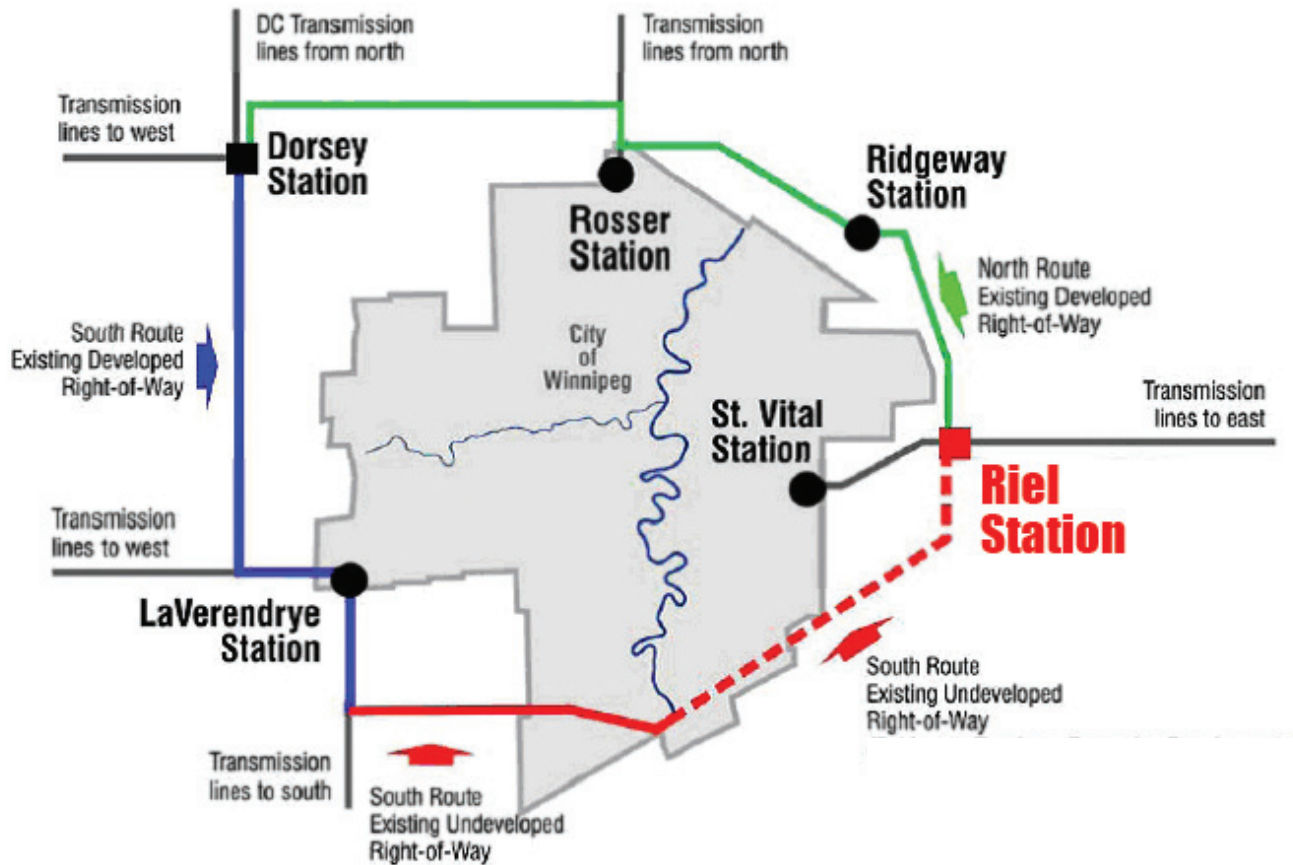

Riel Location & Proximity to other Urban Stations

Appendix 1

1: Overview of Manitoba Hydro's Transmission Facilities

Appendix 1

To the Long-Term Development Plan - 2014
for Manitoba Hydro's Electrical Transmission System

Overview of Manitoba Hydro's Transmission Facilities

Manitoba Hydro's transmission and distribution facilities deliver electrical energy from the generating stations to consumers. Transmission and distribution facilities can be broken down into six categories:

- Generation Outlet Transmission Facilities
- High voltage DC (HVDC) Transmission Facilities
- Interconnection Transmission Facilities
- Network Transmission Facilities
- Distribution Facilities

Generation Outlet Transmission Facilities

Manitoba Hydro's generation outlet transmission facilities transfer electrical energy from the generating stations to the transmission system using short, low-voltage bus work, voltage step-up transformers, high-voltage transmission lines that connect to the grid, and associated equipment.

About 90% of Manitoba Hydro's hydraulic generating capacity is supplied by generating stations in the northern part of the province. A small portion of this generation (19%) is fed directly to the northern AC transmission system, which serves northern areas. The rest (81%) is connected to an isolated 138/230 kV transmission system known as the northern collector system via facilities consisting of 13.8 kV transmission lines and 13.8/138 kV or 13.8/230 kV step-up transformers. The collector system connects ac to the dc converter stations at Radisson (138 kV) and Heday (230 kV). Two high-voltage direct current (HVDC) lines connect to the Radisson and Heday Converter Stations to Dorsey Converter Station, on the outskirts of Winnipeg. From there, the electricity is distributed to much of southern Manitoba through the southern AC transmission system.

The remaining 10% of hydraulic generation is supplied by generating stations in the southern part of the province, including the Winnipeg River plants. Generation outlet transmission facilities for the Winnipeg River plants consist of 6.9 kV, 11 kV, and 13.8 kV transmission stepped up to 69 kV and 115 kV transmission lines. Voltage step-up transformers integrate the supplied energy into the Manitoba Hydro southern AC transmission system.

A privately owned 99 MW wind farm near the town of St. Leon is connected to Manitoba Hydro's network via a direct connection to the 230 kV at St. Leon station.

Also a privately owned 138 MW wind farm near the town of St. Joseph is connected to Manitoba Hydro's network via a direct connection to the 230 kV at Letellier station.

The rest of the power generated by Manitoba Hydro is from thermal generating stations in southern Manitoba. Selkirk Generating Station is fueled by natural gas, while Brandon Generating Station contains two units fueled by natural gas and one fueled by coal. Generation outlet transmission facilities for Selkirk and Brandon consist of 13.8 kV transmission, stepped up to 115 kV.

High Voltage DC (HVDC) Transmission Facilities

The tremendous hydroelectric potential of the Nelson River in northern Manitoba has been appreciated by power planners since the turn of the last century. It was not until the 1960s, however, when the high voltage direct current (HVDC) technology became available for the long-distance transmission of electricity, that it became feasible to develop the Nelson. Manitoba Hydro has since become world renowned for its research and development in HVDC transmission.

DC is used for long distance transmission because it offers certain advantages over AC. Although DC transmission requires converter stations at either ends, per length cost of the associated transmission line (construction and energy losses) are considerably lower.

Manitoba Hydro's Generating Stations and Transmission System

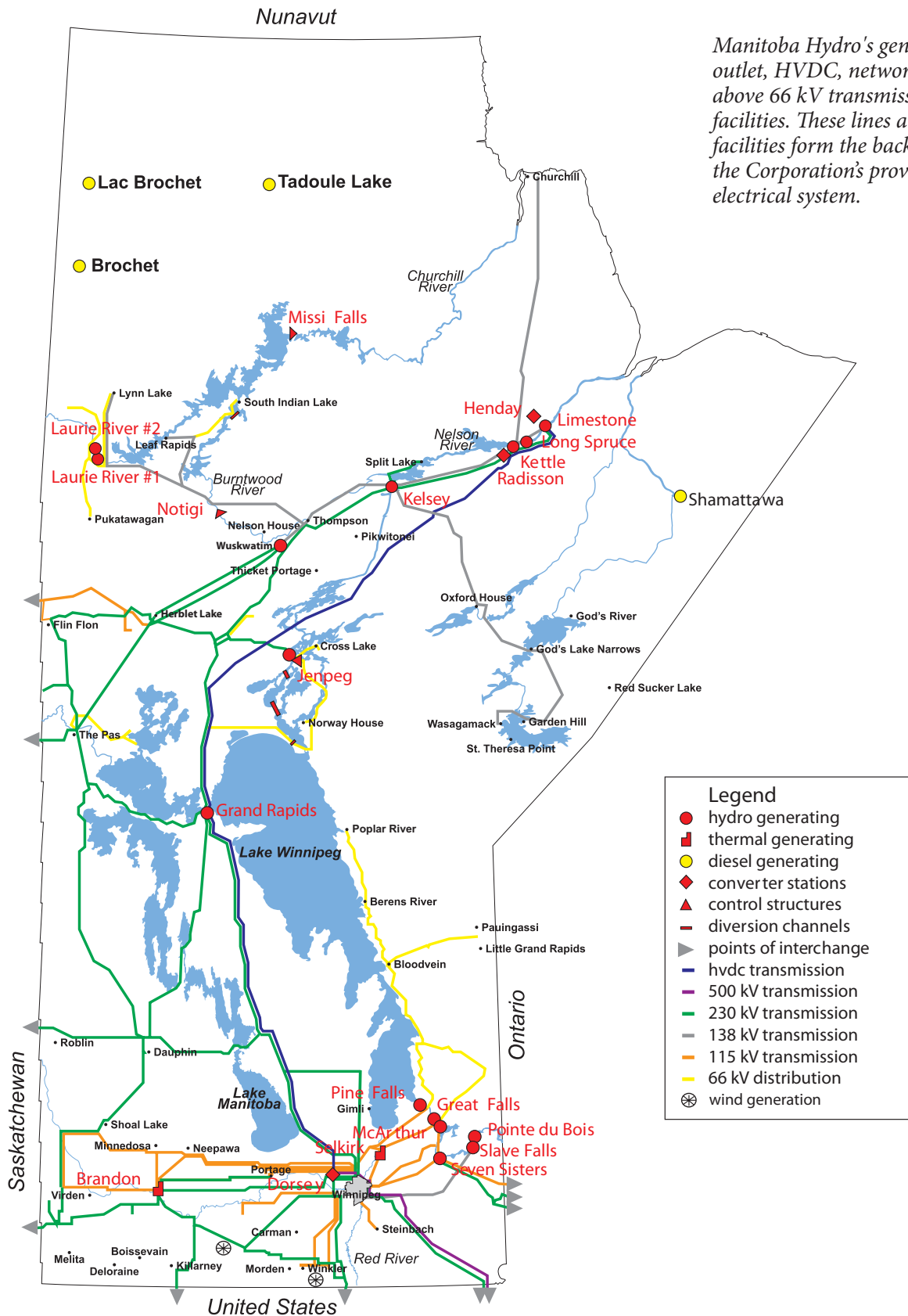

Manitoba Hydro's generation outlet, HVDC, network, and above 66 kV transmission facilities. These lines and facilities form the backbone of the Corporation's provincial electrical system.

Legend

- hydro generating
- thermal generating
- diesel generating
- ◆ converter stations
- ▲ control structures
- diversion channels
- ▶ points of interchange
- hvdc transmission
- 500 kV transmission
- 230 kV transmission
- 138 kV transmission
- 115 kV transmission
- 66 kV distribution
- ⊗ wind generation

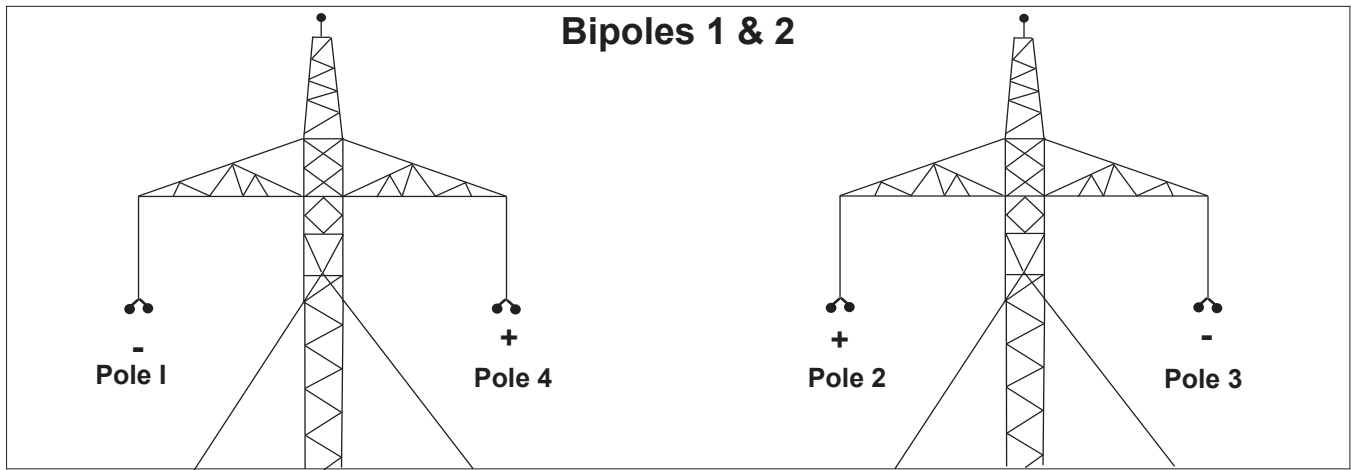

Manitoba Hydro’s HVDC transmission facilities consist of two bipolar transmission systems called Bipole I and Bipole II. The term “bipole” refers to a positive (+) pole and a negative (-) pole. Each pole consists of two conductors, 4 cm in diameter, that are supported by steel transmission towers.

Bipole I is rated to transmit 1854 MW of electricity at a voltage of ± 463.5 kV. Bipole II is rated at 2000 MW at ± 500 kV.

Manitoba Hydro’s two bipolar transmission lines consist of steel towers that follow a 900 km route from Gillam southward through the Interlake region. The southern terminus of both transmission lines is Dorsey Converter Station at Rosser, northwest of Winnipeg.

Bipole I has its northern terminus at Radisson Converter Station near Gillam; Bipole II extends another 42 km northeast to the Henday Converter Station.

The DC power is converted back to AC power at Dorsey for transmission via Manitoba Hydro’s southern AC network. This network feeds Manitoba’s major load centres as well as most of the interconnection transmission facilities that supply neighbouring provinces and the U.S.

Interconnection Transmission Facilities

Manitoba Hydro’s interconnection transmission facilities allow for the economic exchange of electricity between neighbouring electrical systems.

Manitoba Hydro’s primarily hydraulic generation system usually produces surplus energy. Interconnection transmission facilities make it possible to export power surplus to Manitoba load.

Interconnection transmission facilities also allow Manitoba Hydro to import power during periods of drought and supply shortages in Manitoba, thereby strengthening the provincial electric system and lowering the required investment in generation facilities.

US Connections

The Manitoba electric system is connected to the United States electric system via three 230 kV transmission lines and one 500 kV transmission line; namely:

- Letellier to Drayton, ND 230 kV line (62 km),
- Richer to Moranville, MN 230 kV line (124 km),
- Glenboro to Rugby, ND 230 kV line (190 km),
- Dorsey to Forbes, MN 500 kV line (537 km)

The maximum design power transfer capability from Manitoba to the U.S. is 2100 MW, excluding a Transmission Reliability Margin (TRM) of 75 MW.

The maximum design power transfer capability from the U.S. to Manitoba is 700 MW.

The maximum flow in the southern direction is considerably higher than the northern direction. Critical contingency used in establishing the transfer level is the loss of the Dorsey to Forbes 500 kV line. For the loss of the line when exporting, the Manitoba Hydro HVDC system power is rapidly reduced by a special protection system to prevent cascade tripping of the remaining 230 kV lines. This feature allows the export capability to be much higher than the import capability, where this feature is not available.

Saskatchewan Connections

The Manitoba electric system is connected to the Saskatchewan electric system via three 230 kV interconnection transmission lines and two 115 kV interconnection transmission lines, namely:

- Reston to Boundary Dam, SK 230 kV line (169 km),
- Roblin South to Yorkton, SK 230 kV line (80 km)
- Ralls Island to E.B. Campbell, SK 230 kV line (169 km)
- Border to Island Falls, SK 115 kV lines (61 km)

The maximum design power transfer level between Manitoba and Saskatchewan is 105 MW, excluding a TRM of 75 MW.

Ontario Connections

Manitoba's electric system is interconnected to Ontario's via two phase-shifted 230 kV transmission lines and one non-synchronous 115 kV transmission line.

The 230 kV interconnections join the Whiteshell and Kenora (129 km) and have a design power transfer level from Manitoba to Ontario of 200 MW, excluding a TRM of 25 MW. The phase-shifting transformers have a ± 180 -degree control range for optimum control of power transfer between Manitoba and Ontario.

The 115 kV connection, 141 km long, join Seven Sisters and Kenora. This line can be used only to send up to 75 MW of power to Ontario by connecting Seven Sisters Falls generating units to the line. Normally, it is operated open at the border. The Manitoba Hydro portion is connected to the 115 kV system and serves Manitoba loads at Brereton and Star Lake.

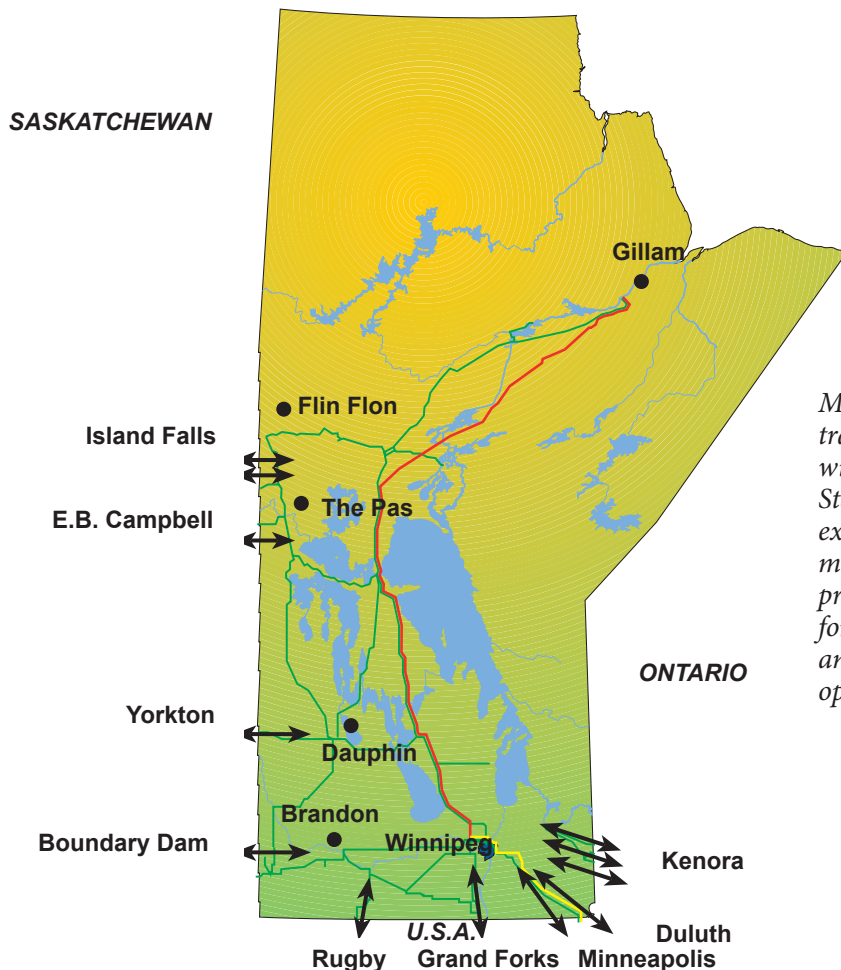

Manitoba Hydro's 12 interconnection transmission lines, which connect our system with Ontario, Saskatchewan, and the United States. These "tie" lines, like mammoth extension cords, provide access to export markets for selling surplus electricity. They also provide a means of receiving backup power for the province during droughts, emergencies, and periods of high demand or economic opportunities.

Network Transmission Facilities

A bulk AC transmission network of power lines extends across the province, operating at 115 kV, 138 kV and 230 kV.

115 kV: Manitoba Hydro operates 2,900 km of 115 kV transmission lines, most of them in the southern part of the province. The lines feed sub-transmission facilities, as well as some major loads, including Winnipeg, Flin Flon (in north-west Manitoba), Portage la Prairie (in south-central Manitoba), Morden (in south-central Manitoba) and communities in south-east Manitoba.

138 kV: Nearly 1400 km of 138 kV transmission lines serve the province's small northern communities and feed Manitoba Hydro's HVDC transmission facilities. The 138 kV network branches out from Kelsey Generating Station on the Nelson River and stretches north to Churchill South Station on the shore of Hudson Bay, west to Lynn Lake station near the Saskatchewan-Manitoba border, and east to Wasagamack station near the Manitoba-Ontario border.

230 kV: Most of Manitoba Hydro's electric transmission capacity is provided by 5,000 km of 230 kV transmission system, a relatively new network. Major 230 kV transmission lines are supplied from Dorsey Converter Station. From Dorsey, eight 230 kV transmission lines transmit power to Rosser, Ridgeway, La Verendrye and St. Vital stations in Winnipeg. Four other 230 kV transmission lines transmit power from Dorsey to Cornwallis station in Brandon, St. Leon station in southern Manitoba and Ashern station in the Interlake area. At these stations, power is either stepped down from 230 kV to 115 kV or 66 kV or further transmitted at 230 kV.

Appendix 2

2: Generation and Transmission Proposed and Planned Projects - Scheduled In-Service Dates

Manitoba Hydro
System Planning Department
Generation and Transmission Projects
Scheduled In-Service Dates

New Generation

Keeyask G.S. (7 x 99.3 MW)	2019 - 20
Conawapa G.S. (10 x 148.5 MW)	2029 - 31

Generator Upgrades

Pointe du Bois G.S. return to service	2012 - 15
Pine Falls G.S. re-runner (+14 MW)	2015 - 19
Pointe du Bois G.S. redevelopment (+41 MW)	on hold

Transmission for Generation

Keeyask - KN36 tap 138 kV TL (constr power)	2015 06
Henday - Keewatinohk 230 kV TL (4 ccts)	2018 07
Longspruce - Conawapa 230 kV TL (1 cct)	2018 07
Bipole III ±500 kV TL	2018 07
Keeyask - Radisson 138 kV TL (3 ccts)	2019 09

Central AC Transmission System

Ridgeway - Rover 66 kV TL	2014 10
Laverendrye - St. Vital 230 kV TL	2018 02
St Vital - Letellier 230 kV TL	2017 07
Ridgeway - Richer, Sect. R49R into Riel	2016 09
Dorsey - US 500 kV tie line (2nd)	2020 05
Sectionalize St Vit - Letellier 230 kV at Grunthal	2020 10
Laverendrye - Riel 230 kV TL	2024 05
Riel - St. Vital 230 kV TL	2024 05

Transmission Line Taps for New DSC's

Selkirk DSC (115 kV - 66 kV)	2014 04
Tyndal DSC (115 kV - 66 kV)	2014 10
Anola DSC (115 kV - 66 kV)	2015 01
Ile des Chene DSC (115 kV - 66 kV)	2015 06

Eastern AC Transmission System

Pointe du Bois - Whiteshell 115 kV TL (1 cct)	2017 04
WT34 115 kV line mods	2015 10
Pine Falls - Manigotagan 115 kV TL	2016 10

Converter/ FACTS/ Controls/ Reactive Power

Riel 230 kV 3 X 73.4 Mvar capacitors	2014 10
Keewatinohk and Riel - 2000 MW converters each	2018 07
Keewatinohk and Riel - 800 Mvar ac filters each	2018 07
Dorsey Bnk 51, 500/230/46 kV, 73.4 Mvar tert. caps	2020 05

Western AC Transmission System

Neepawa - Sectionalize 230 kV line D54C	2015 03
Portage - Dorsey 230 kV TL (2nd circuit)	2017 04

Transmission Stations

Keeyask 138 kV Switching Station	2019 09
Neepawa 230/66 kV new station	2015 03
Pointe 115/66 kV bank 8 new 60 MVA transformer	2017 04
Rockwood East 230/115 kV new station and transformer	2015 11
Souris East 230/66 kV 2nd transformer	2019 04
Laverendrye 230/66 kV new transformer	2019 09
Reston Station new 230 kV ring breaker	2020 03
Manigotagan 115/66 kV new station & transformer	2016 10
Riel 500/230 kV new station and transformer	2014 10
Stanley 230/66 kV stn permanent transformer	2016 10
Brandon Crocus New 30 MVA Transformer	2018 10
Ashern 230/66 kV new bank transformer	2017 02
Grunthal 230/66 kV new station & transformers	2020 10



For More Information

**Please contact:
Manager, System Planning Department
204-360-3113**

Manitoba Hydro
P.O. Box 7950
820 Taylor Ave.
Winnipeg MB R3C 0J1

December 2014
Printed in Canada

