

Report R164-08 - *DRAFT*

***MHEB Group TSR System Impact Study
Out-Year Power Flow Analysis
MH to US Requests***

Prepared for

Midwest ISO

Submitted by:
Douglas R. Brown
Hari Singh
Lengcheng Huang

Revised June 26, 2009

Siemens PTI Project P/21-113318

Revision History

Date	Description
3/11/2009	Original
6/26/2009	General revisions, removed Option 2, requests A339 and A406 have withdrawn; request A340 approved for 7 MW of service

Contents

Legal Notice.....	iii
Executive Summary	v
Transmission Upgrade Options.....	vi
Transmission Service Impacts	vi
Constraint Mitigation Costs.....	ix
Section 1 Steady-State Analysis	1-1
1.1 Methodology.....	1-1
1.2 Computer Programs	1-1
1.3 Model Development.....	1-1
1.3.1 Summer Peak Benchmark Case	1-1
1.3.2 Summer Peak Study Cases.....	1-7
1.4 Contingency Criteria	1-9
1.5 Monitored Facilities	1-9
1.6 Reliability Margins	1-10
1.7 Performance Criteria.....	1-10
1.8 Network Analysis Results	1-11
1.8.1 Impact on System Losses	1-11
1.8.2 Transmission Service Impacts	1-11
Appendix A MTEP Projects Applied from MOD	A-1
Appendix B Transmission Upgrade Options	B-1
Appendix C Network Analysis Results	C-1

This page intentionally left blank.

Legal Notice

This document was prepared by Siemens Energy, Inc., Power Technologies International (Siemens PTI), solely for the benefit of Midwest ISO. Neither Siemens PTI, nor parent corporation or its or their affiliates, nor Midwest ISO, nor any person acting in their behalf (a) makes any warranty, expressed or implied, with respect to the use of any information or methods disclosed in this document; or (b) assumes any liability with respect to the use of any information or methods disclosed in this document.

Any recipient of this document, by their acceptance or use of this document, releases Siemens PTI, its parent corporation and its and their affiliates, and Midwest ISO from any liability for direct, indirect, consequential or special loss or damage whether arising in contract, warranty, express or implied, tort or otherwise, and irrespective of fault, negligence, and strict liability.

This page intentionally left blank.

Executive Summary

Several requests for long term firm transmission service have been made under the Midwest ISO's Open Access Transmission and Energy Markets Tariff. This report presents the results of a steady-state power flow analysis performed on a summer peak scenario to evaluate the requests for transmission service shown in Table E-1. These requests seek to reserve 1130 MW of transmission service from Manitoba Hydro to various sinks in US.

Table E-1: MHEB Group TSR MH to US Requests

Oasis Ref No	Service Type	Start time	Stop Time	POR	POD	Requested Capacity	Queue Date	Study Number
76703536	Network	Nov-2014	Nov-2024	MHEB-MISO	GRE	200	12/7/2006	A388
76703535	Network	Apr-2008	Apr-2013	MHEB-MISO	NSP	30	1/26/2007	A351
76703671	Network	Jun-2017	Jun-2027	MHEB-MISO	WPS	500	6/12/2007	A380
76703672	Network	Jun-2017	Jun-2037	MHEB-MISO	MP	250	7/6/2007	A383
76703686	Network	Jun-2017	Jun-2027	MHEB-MISO	NSP	50	4/17/2008	A416
76703687	Network	Jun-2017	Jun-2027	MHEB-MISO	WEC	100	4/17/2008	A417

Total (MW) 1130

This study was performed by Siemens PTI under the direction of Midwest ISO and an Ad Hoc Study Group consisting of American Transmission Company (ATC LLC), Basin Electric Power Cooperative (BEPC), Dairyland Power Cooperative (DPC), Great River Energy (GRE), Manitoba Hydro (MHEB), Minnesota Power (MP), Minnkota Power Cooperative (MPC), Otter Tail Power (OTP), Western Area Power Administration (WAPA) and Xcel Energy (XEL).

Transmission Upgrade Options

The transmission upgrade options proposed by the ad hoc study group are summarized in Table E-2 along with their cost estimates. The cost estimates are for the new 500 kV transmission lines only and are based on \$/mile costs taken from the JCSP 2008 Interim Stakeholder Meeting Introduction Presentation¹ and adjusted down from 2024 dollars to 2018 dollars using a 3% escalation factor. The costs for series compensation, transformers, line terminations and other required substation equipment are not included in this preliminary estimate. These costs will be further developed and refined in the Facilities study.

System diagrams depicting the two proposed upgrade options are included in Appendix B.

Table E-2:-Transmission Upgrade Options

Option No.	Project	Cost in 2018 ¹
1	Dorsey – Maple River 50% series compensated 500 kV line with one 500/345 kV, 1200 MVA transformer at Maple River. Maple River – Helena 50% series compensated 500 kV line terminated with two 500/345 kV, 1200 MVA transformers at Helena.	\$1.035 B
3	Dorsey – King 50% series compensated 500 kV line terminated via two 500/345 kV, 1200 MVA transformers at King.	\$955 M

Note 1: Cost estimates are for transmission lines only

The transmission upgrade options evaluated in this study do not include shunt reactors to compensate for capacitive generation on the new 500 kV lines. As a result, steady-state voltage is around 1.2 per unit at the series capacitor on the Dorsey-King 500 kV line. Both Option 1 and Option 3 will require shunt reactors on the 500 kV line to control steady-state voltages.

Transmission Service Impacts

A benchmark power flow model representing 2017 summer peak system conditions was created without the requested transmission service. TSR study cases were created by adding the requested transmission service to the benchmark case along with one of two transmission upgrade options. A nonlinear (ac) contingency analysis was performed on the benchmark and study cases and the incremental impact of the requested transmission service was evaluated by comparing flows and voltages without and with the service.

Linear (dc) analysis was used to calculate distribution factors for each TSR. These distribution factors and the results of the nonlinear contingency analysis were used to identify significantly affected facilities and to calculate the loading on those facilities before and after each TSR.

Facilities on which one or more TSR have a significant thermal impact are summarized in Table E-3. A thermal impact is considered significant if the facility loading exceeds the

¹ http://www.midwestmarket.org/publish/Document/81d7e_11b6e66e758_-795e0a48324a/Interim%20Presentation.pdf?action=download&_property=Attachment

applicable limit and the TSR has a PTDF greater than 5% or an OTDF greater than 3% for the overloaded facility.

Table E-3: Significantly Affected Facilities

Monitored Element	Owner	Rating (MVA)	Option 1 Study Case	Option 3 Study Case	Contingency
Saratoga-Petenwell 138 kV line	ATC	72.2	X	X	Multiple Contingencies: C:ATC-ARP-OG1 C:ATC-ARP-OG2 C:ATC-ZN1-2
East Krok-Kewaunee 138 kV line	ATC	272.6	X	X	C:North Appleton-Kewaunee 345 kV line
Eau Claire-Wheaton 161 kV line	NSP	300	X	X	C:B_XEL_KING-EAU_CLA
SW Eau Claire – Alma 161 kV line	DPC	194	X	X	C:B_XEL_KING-EAU_CLA
Jackson 161/69 kV transformer	NSP	47	X	X	Base Case and Multiple Contingences*: C:605292 MONROCO8 605298 SPARTA28 C:605322 TREMVAL8 605328 BLAIR 8 C:602029 TREMVAL5 605322 TREMVAL8

* Only worst 3 contingencies are listed

The significantly affected facilities that qualify as thermal constraints for each TSR are identified below.

A388 (200 MW MHEB-MISO to GRE)

A388 is a request for 200 MW of network transmission service from MHEB-MISO to GRE. No constraints were identified for A388 for either of the transmission upgrade option.

A351 (30 MW MHEB-MISO to NSP)

A351 is a request for 30 MW of network transmission service from MHEB-MISO to NSP. No constraints were identified for A351 for either of the transmission upgrade option.

A380 (500 MW MHEB-MISO to WPS)

A380 is a request for 500 MW of network transmission service from MHEB-MISO to WPS. A380 constraints are summarized in Table E-4.

Table E-4: A380 Flow-Based Analysis Constraints

Study	Constraint	Rating (MVA)	Significant Thermal Impacts - Highest Loading ¹	
			Option 1	Option 3
A380	Eau Claire-Wheaton 161 kV line	300	107.8%	108.1%
	SW Eau Claire – Alma 161 kV line	194	106.9%	104.8%
	Saratoga-Petenwell 138 kV line	72.2	137.3%	136.7%
	East Krok-Kewaunee 138 kV line	272.6	101.2%	100.8%

A383 (250 MW MHEB-MISO to MP)

A383 is a request for 250 MW of network transmission service from MHEB-MISO to MP. No constraints were identified for A383 for either of the transmission upgrade option.

A416 (50 MW MHEB-MISO to NSP)

A416 is a request for 50 MW of network transmission service from MHEB-MISO to NSP. A416 constraints are summarized in Table E-5.

Table E-5: A416 Flow-Based Analysis Constraints

Study	Constraint	Rating (MVA)	Significant Thermal Impacts - Highest Loading ¹	
			Option 1	Option 3
A416	SW Eau Claire – Alma 161 kV line	194	110.1%	107.9%
	Jackson 161/69 kV transformer	47	160.8%	160.2%

A417 (100 MW MHEB-MISO to WEC)

A417 is a request for 100 MW of network transmission service from MHEB-MISO to WEC. A417 constraints are summarized in Table E-6.

Table E-6: A417 Flow-Based Analysis Constraints

Study	Constraint	Rating (MVA)	Significant Thermal Impacts - Highest Loading ¹	
			Option 1	Option 3
A417	Eau Claire-Wheaton 161 kV line	300	104.2%	104.6%
	Saratoga-Petenwell 138 kV line	72.2	143.6%	142.8%

Constraint Mitigation Costs

Estimated costs for resolving each of the TSR constraints during Summer Peak conditions are summarized in Table E-7. Impacted facilities are common to both Option 1 and Option 3. The costs are good faith estimates provided by the affected Transmission Owners and will be further developed and refined in the Facility Study.

Table E-7: Mitigation costs for constraints during Summer Peak conditions

Thermal Constraint	Mitigation required	Costs
Saratoga-Petenwell 138 kV line	Reconductor 22.7 mi of the line	\$2,927,167
East Krok-Kewaunee 138 kV line	Replacing substation equipment at E. Krok	\$1,000,000
Eau Claire-Wheaton 161 kV line	Reconductor 4.3 mi with 795 ACSS conductor	\$0 ¹
SW Eau Claire – Alma 161 kV line	TBD	TBD
Jackson 161/69 kV transformer	Replace with larger 161/69 kV transformer	\$900,000
Total		\$4,827,167

Note: 1. Planned project exists for mitigation, TSRs not responsible for cost

This page intentionally left blank.

Section
1

Steady-State Analysis

1.1 Methodology

A benchmark power flow model representing 2017 Summer Peak system conditions was created without the requested transmission service. TSR study cases were created by taking the benchmark case and modeling the requested transmission service along with one of the transmission upgrade options. A nonlinear (ac) contingency analysis was performed on the benchmark and study cases and the incremental impact of the requested transmission service was evaluated by comparing flows and voltages without and with the service.

Linear (dc) analysis was used to calculate distribution factors for each TSR. These distribution factors and the results of the nonlinear contingency analysis were used to identify significantly affected facilities and to calculate the loading on those facilities before and after each TSR.

1.2 Computer Programs

Analysis was performed using PSS[®]E version 30.3 and PSS[®]MUST version 8.3.2.

1.3 Model Development

1.3.1 Summer Peak Benchmark Case

A summer peak benchmark case without the study TSRs and associated transmission upgrades was developed. The source was a 2017 summer peak MTEP08 case that includes the future transmission upgrades from MTEP 08 Appendices A and B listed in Appendix A of this report. Projects in MTEP 08 Appendix B have not yet been studied through the MTEP cost-allocation process. If any of the projects in MTEP 08 Appendix B do not get developed, as per the identified need (in MTEP), the study TSRs would be reevaluated to determine if they are potentially responsible for the cost of those projects or appropriate alternatives. In addition to future transmission upgrades, the benchmark case was updated to include all existing MH to US firm transmission service commitments, prior-queued transmission service requests (confirmed and study status) not already included in the MTEP case, network resource generation and miscellaneous updates and corrections as described in the following sections.

The benchmark power flow case was solved with transformer tap adjustment enabled, switched shunt adjustment enabled, area interchange enabled (ties only), phase shifter adjustment enabled and dc tap adjustment enabled.

1.3.1.1 Existing MH to US Firm Transmission Service

The summer peak benchmark case includes all existing firm transmission service commitments on the MHEX_S (Manitoba Hydro Export South) interface, as listed in Table 1-1 below.

Table 1-1: Existing Firm Transmission Service on MHEX_S Interface

TSR Ref# (MH OASIS)	POR	POD	Capacity (MW)	Start Time	End Time	Service
76703190	MH	NSP	30	11/1/2008	12/1/2009	YEARLY FIRM PTP
76703232	MH	NSP	30	5/1/2009	5/1/2012	YEARLY FIRM PTP
76703181	MH	MP	50	5/1/2009	5/1/2015	YEARLY FIRM PTP
76703231	MH	GRE	50	11/1/2008	11/1/2014	YEARLY FIRM PTP
76703238	MH	OTP	55	11/1/2008	5/1/2010	YEARLY FIRM PTP
76703207	MH	NSP	64	5/1/2009	5/1/2013	YEARLY FIRM PTP
76703187	MH	NSP	70	11/1/2008	5/1/2011	YEARLY FIRM PTP
76737070	MH	WPS	100	6/1/2009	6/1/2014	YEARLY FIRM PTP
76703186	MH	NSP	100	11/1/2008	5/1/2010	YEARLY FIRM PTP
76703221	MH	NSP	150	5/1/2009	11/1/2009	YEARLY FIRM PTP
76703222	MH	GRE	150	5/1/2009	11/1/2009	YEARLY FIRM PTP
76703218	MH	NSP	200	5/1/2009	11/1/2009	YEARLY FIRM PTP
76703237	MH	NSP	213	11/1/2008	11/1/2009	YEARLY FIRM PTP
76703234	MH	NSP	529	11/1/2008	5/1/2015	YEARLY FIRM PTP
76735261	MH	OTP	50	5/1/2009	5/1/2014	YEARLY FIRM PTP
76739827	MH	NSP	7	5/1/2009	5/1/2014	YEARLY FIRM PTP

Total 1848 MW

The resulting MHEX_S interface flow in the summer peak benchmark case is 1844.5 MW.

1.3.1.2 Prior-Queued WAPA TSRs

The following proposed generating facilities have TSRs under study on the WAPA OASIS and were added to the summer peak benchmark case.

- Culbertson Project GI-0708 + GI-0614a (120+10 MW)
- GI-0704 (240 MW)
- Minot (aka Mallard) Project GI-0503 + GI-0720 (100+25 MW)
- GI-0714 (100 MW)

Table 1-2: Firm TSRs on WAPA OASIS

TSR Ref# (WAPA OASIS)	Capacity (MW)	Start Time	End Time	Service
941998	100	10/1/2006	1/1/2015	YEARLY FIRM NITS
70992013	10	1/1/2008	1/1/2029	YEARLY FIRM NITS
71283528	240	6/1/2009	6/1/2034	YEARLY FIRM NITS
71372179	120	1/1/2009	1/1/2035	YEARLY FIRM NITS
71689351	25	6/1/2009	6/1/2029	YEARLY FIRM NITS
942047	100	10/1/2006	1/1/2015	YEARLY FIRM NITS

Total 595 MW

The aggregate output of these generating facilities (595 MW) is dispatched against generation at Big Bend and Ft. Randall. Groton Unit 1 and Unit 2 are dispatched at 125 MW each.

1.3.1.3 Prior-Queued Midwest ISO TSRs

Table 1-3 shows prior-queued Midwest ISO TSRs and confirmed requests that were added to the summer peak benchmark case using sources and sinks provided by Midwest ISO.

Table 1-3: Midwest ISO TSRs Added to the SUPK Case

OASIS	OASIS #	STUDY	POR	POD	CAPACITY REQUESTED (MW)	START	STOP
MISO	75690167 75690165	A168	MP	NSP	35 (20+15)	6/1/2006 6/1/2006	6/1/2026 6/1/2026
MISO	76541075 76541076	A204	MP	MP	50 (25+25)	2/1/2008 2/1/2011	2/1/2009 2/1/2012
MISO	76109095	A230	WAUE	GRE	108	1/1/2008	1/1/2036
MISO	76414212	A301B	MP	GRE	100	6/1/2006	6/1/2008
MISO	76403280	A304	MHEB	MP	50	5/1/2009	5/1/2015
MISO	76434677	A316	OTP	OTP	50	2/1/2010	11/1/2028
MISO	76463020	A329	OTP	OTP	21	2/1/2007	1/1/2028
MISO	76480654	A335	GRE	GRE	68	4/1/2009	4/1/2029
MISO	76484129 76484130	A338	OTP	OTP	40 (20+20)	4/1/2014	1/1/2028
MISO	76488162	A341	WAUE	GRE	68	1/1/2008	1/1/2036
MISO	76463020	A345	WAUE	NSP	61	6/1/2009	6/1/2029
MISO	76515390	A365	WAUE	GRE	30	1/1/2009	1/1/2022
MISO	76526766	A374	OTP	OTP	49	11/1/2008	11/1/2028
MISO	76484129 76484130	A411	OTP	OTP	98 (50+48)	6/1/2009 10/1/2008	6/1/2069 10/1/2068
MISO	76659803	-	MP-ONT	MP	150	11/01/2008	11/01/2013
MISO	76668811	A373	MP	MP	100	7/1/2010	8/1/2015
MISO	76668831	A373	NSP	MP	100	7/1/2010	8/1/2015
MISO	76668843	A381	GRE	MP	200	7/1/2011	8/1/2016
MISO	76668850	A393	OTP	MP	100	7/1/2010	8/1/2015

1.3.1.4 Midwest ISO Network Resource Generation

The NR generating facilities listed in Table 1-4 were added to the summer peak benchmark case.

Table 1-4: Midwest ISO NR Generation Added to the SUPK Case

MISO Project Number	MISO Queue Number	MISO Queue Date	Control Area	County	Point of Interconnection	Max Output (MW)	Dispatch (MW)
G519	38491-01	19-May-05	MP	Itasca, MN	Blackberry 230/115kV Substation	600	600
G555	38649-02	24-Oct-05	OTP	Stevens, MN	2 miles north of the Morris substation on the Morris - Grand Co. 115 kV line	100	20
G586	38716-02	30-Dec-05	XEL	Lincoln, MN	Xcel New Yankee Sub 34.5 kV	30	6
G593	38755-01	07-Feb-06	ALTW	Jackson, MN	Lakefield Junct. - Triboji 161 kV line	100	20
G602	38771-01	23-Feb-06	XEL	Nobles, MN	Nobles County Sub along 161 kV NSP trans line	31.5	6.3
G618	38818-02	11-Apr-06	OTP	Yellow Medicine, MN	Burr Jct to Toronto 115 kV line located 5 miles from Camby	138	27.6
G619	38821-01	14-Apr-06	OTP	Otter Tail, MN	41 kV at Tamarac Sub (GRE)	50	10
G626	38832-02	25-Apr-06	XEL	Brown, MN	Morgan to Sleepy Eye line #0719 69 kV	31.5	6.3
G691	39006-02	16-Oct-06	XEL	Vernon, WI	Westby - Cashton tap 69 kV line	50	10
G767	39161-01	20-Mar-07	WAPA	Fallon, MT	Baker 60 kV	30	6
G843	39318-01	24-Aug-07	OTP	Otter Tail, MN	R37T131 Sec 3 Parkers Prairie Twp near the junction of State Highway 29 and Co Rd 138	100	20
G858	39329-01	04-Sep-07	XEL	Stearns, MN	Xcel Black Oak Switching Station on County Road 186 in Section 6 of Grove Township	38	7.6
G875	39364-03	09-Oct-07	OTP	Kittson/ Marshall, MN	115 kV line between Donaldson and Warsaw	80	16
G904	39388-01	02-Nov-07	OTP	Rolette, ND	Rugby-Glenboro 230kV Line	150	30
G930	39426-03	10-Dec-07	XEL	Sherburne, MN	Sherco Substation	120	120

1.3.1.5 Manitoba Hydro (MH) System Updates

The following transmission and generation facilities were added to the summer peak benchmark case to update the MH system representation and to ensure adequate generation reserves are available for sourcing the study TSRs:

- Bipole 3 and associated facilities at Riel
- Dorsey-Riel 500 kV circuit #2
- Dorsey-Portage 230 kV line
- Laverendrye-St Vital 230 kV line
- Letellier-St Vital 230 kV line
- Pointe du Bois rebuilt generating plant at 120 MW
- St Joseph wind farm (2 x 150 MW)
- Keeyask generating plant (7 x 90 MW)
- Conawapa generating plant (10 x 130 MW)

The aggregate injection from the three HVDC bipoles was set at 3400 MW in the benchmark case as follows:

- Bipole 1 = 800 MW
- Bipole 2 = 940 MW
- Bipole 3 = 1660 MW

1.3.1.6 Miscellaneous Updates and Corrections

Table 1-5 shows other miscellaneous model updates.

Table 1-5: Miscellaneous Updates and Corrections

Area	Description
ATC	Redispatched generation in control areas ALTE and WEC so that area slack generator output is within limits
MH, SPC	Reduced net flow on MH-SPC ties to 0 MW
MH	Add 3x73.4 MVar shunt capacitors on 46-kV tertiary of Riel 500/230-kV transformer.
WAPA	Topology corrections at Penn 115 kV and Hilken 230 kV buses
WAPA	Purged extraneous 230/115/13.2 kV transformer at Winger and Canby 345 kV-Granite Falls 230 kV line.
WAPA	Dispatched Leland Olds Unit #1 at 225 MW
XEL/ WAPA	Turned on Forbes SVC and adjust SVC output at Forbes, Fargo and Watertown
XEL	Removed extraneous BRIGO facilities
XEL	Dispatched River Falls generation
XEL	Updated facility ratings for M602F, F601C and Coon Creek – Kolman Lake
XEL	Changed Forbes SVC rating from +400/-450 Mvar (10 second capability) to +110/-149 Mvar (continuous).

1.3.2 Summer Peak Study Cases

TSR study cases were created by taking the benchmark case and modeling the requested transmission service along with one of the transmission upgrade options. Losses for each TSR study case are summarized in Appendix B.

1.3.2.1 Source and Sinks for Study TSRs

The TSR source is the Dorsey inverter station and the 1130 MW aggregate study TSRs were sunk by increasing the injection from the existing two HVDC bipoles at Dorsey from 1740 MW in the benchmark case to 2870 MW in the study case. The study TSRs were sunk at the generators shown in Table 1-6.

Table 1-6: MH to US TSR Sinks

Bus #	Generator Name	MW
REMOVED		

1.3.2.2 Transmission Upgrade Options

The transmission upgrade options proposed by the ad hoc study group are summarized in Table 1-7.

System diagrams depicting the proposed upgrade options are included in Appendix B.

Table 1-7: Transmission Upgrade Options

Option No.	Project
1	Dorsey – Maple River 50% series compensated 500 kV line with one 500/345 kV, 1200 MVA transformer at Maple River. Maple River – Helena 50% series compensated 500 kV line terminated with two 500/345 kV, 1200 MVA transformers at Helena.
3	Dorsey – King 50% series compensated 500 kV line terminated via two 500/345 kV, 1200 MVA transformers at King.

The transmission upgrade options evaluated in this study do not include shunt reactors to compensate for capacitive generation on the new 500 kV lines. As a result, steady-state voltage is around 1.2 per unit at the series capacitor on the Dorsey-King 500 kV line as noted below. Both Option 1 and Option 3 will require shunt reactors on the 500 kV line to control steady-state voltages.

OPTION 3 BUSES WITH VOLTAGE GREATER THAN 1.1000:

BUS#	X--	NAME	--X	BASKV	V (PU)	V (KV)
601061		MIDCOMP-N		500.00	1.1900	595.01
601062		MIDCOMP-S		500.00	1.1415	570.74

1.4 Contingency Criteria

A variety of system conditions are considered for the steady-state analysis.

- NERC Category A with system intact (no contingencies)
- NERC Category B contingencies
 - Outage of single element 100 kV or higher (B.2 and B.3) associated with single contingency event in the following areas: ATCLLC (WEC, ALTE, WPS, MGE, UPPC), DPC, GRE, ITC Midwest, MH, MP, OTP, SMMPA, WAPA, XEL
 - Outage of multiple-elements 100 kV or higher (B.2 and B.3) associated with single contingency event in the Dakotas, Manitoba, Minnesota, Wisconsin

Contingencies that simulate the outage of new 500 kV facilities associated with upgrade Option 1 or Option 3 do not trigger HVDC reduction. Existing 500 kV and 230 kV triggers to the Manitoba Hydro HVDC power order reduction scheme were simulated in the contingency analysis.

For all contingency and post-disturbance analyses, the power flow cases are solved with transformer tap adjustment and switched shunt adjustment enabled, area interchange adjustment disabled, and phase shifter adjustment plus dc tap adjustment disabled.

1.5 Monitored Facilities

Monitored facilities and associated thermal and voltage limits are shown in Table 1-8.

Table 1-8: Monitored Facilities and Limits

Owner/ Area	Monitored Facilities	Thermal Limits ¹		Voltage Limits
		Pre-Disturbance	Post-Disturbance	
ATC LLC	69 kV and above	95% of Rate A	95% of Rate B	1.10/0.90
BEPC	69 kV and above	100% of Rate A	100% of Rate A	1.10/0.90
DPC	69 kV and above	100% of Rate A	100% of Rate A	1.10/0.90
GRE	69 kV and above	100% of Rate A	100% of Rate B	1.10/0.92/0.90 ²
ITCMW	69 kV and above	100% of Rate A	100% of Rate B	1.10/0.90
MDU	69 kV and above	100% of Rate A	100% of Rate B	1.10/0.90
MEC	69 kV and above	100% of Rate A	100% of Rate A	1.10/0.90
MH	69 kV and above	100% of Rate A	100% of Rate B	1.15/1.10/0.94/0.90 ³
MP	69 kV and above	100% of Rate A	100% of Rate B	1.05/0.95
MPC	69 kV and above	100% of Rate A	100% of Rate A	1.10/0.90
MRES	69 kV and above	100% of Rate A	100% of Rate A	1.10/0.90
NWPS	69 kV and above	100% of Rate A	100% of Rate A	1.10/0.90
OTP	69 kV and above	100% of Rate A	100% of Rate B	1.10/0.90

Owner/ Area	Monitored Facilities	Thermal Limits ¹		Voltage Limits
		Pre-Disturbance	Post-Disturbance	
RPU	69 kV and above	100% of Rate A	100% of Rate A	1.10/0.90
SMMPA	69 kV and above	100% of Rate A	100% of Rate B	1.10/0.90
SPC	69 kV and above	100% of Rate A	100% of Rate A	1.10/0.90
WAPA	69 kV and above	100% of Rate A	100% of Rate A	1.10/0.90
XEL	69 kV and above	100% of Rate A	100% of Rate B	1.10/0.90

Note 1: PSSE Rate A, Rate B or Rate C

Note 2: 0.92 limit applies to load serving buses

Note 3: Limits dependent on nominal bus voltage

1.6 Reliability Margins

Flowgate ratings for this out-year analysis are based on facility ratings and do not consider capacity benefit margin (CBM) or transmission reliability margin (TRM). All other system elements were monitored as shown in Table 1-8.

1.7 Performance Criteria

A branch or flowgate is considered a significantly affected facility if both of the following conditions are met for the transmission service under study:

- 1) the facility is loaded above its applicable normal or emergency rating in the study case, and
- 2) the power transfer distribution factor (PTDF) is greater than 5% or the outage transfer distribution factor (OTDF) is greater than 3% for the overloaded facility.

Distribution factors for each TSR are calculated using linear (dc) analysis.

A voltage impact is considered significant if both of the following conditions are met for the transmission service under study:

- 1) the bus voltage is outside of applicable normal or emergency limits in the study case, and
- 2) the impact of the requested service on bus voltage is greater than 0.01 per unit.

1.8 Network Analysis Results

1.8.1 Impact on System Losses

The combined impact of the transmission upgrades and the aggregate TSRs (1130 MW) on system losses is shown in Appendix C, Table C-1. For each upgrade option, the change in system losses within the study area is tabulated. Although the real power losses occurring in the upgrade facilities comprising Option 1 are lower than in Option 3, the net change in system real power losses (compared to the benchmark case) is higher for Option 1 (237 MW increase) compared to Option 3 (223 MW increase).

1.8.2 Transmission Service Impacts

Table C-2 in Appendix C shows the combined impact of the transmission upgrades and the aggregate TSRs (1130 MW) on facilities impacted by one or more TSR. A thermal impact is considered significant if the facility loading exceeds the limit shown in Table 1-8 and the distribution factor exceeds the threshold given in Section 1.7. There are no significant voltage impacts attributable to any TSR.

1.8.2.1 A388 (200 MW MHEB-MISO to GRE)

A388 is a request for 200 MW of network transmission service from MHEB-MISO to GRE. With respect to request A388, no significantly affected facilities were identified for either of the transmission upgrade options.

1.8.2.2 A351 (30 MW MHEB-MISO to NSP)

A351 is a request for 30 MW of network transmission service from MHEB-MISO to NSP. With respect to request A351, no significantly affected facilities were identified for either of the transmission upgrade options.

1.8.2.3 A380 (500 MW MHEB-MISO to WPS)

A380 is a request for 500 MW of network transmission service from MHEB-MISO to WPS. Request A380 has a significant thermal impact on the facilities shown in Table 1-11.

With respect to request A380, all the four significantly affected facilities are common to both transmission upgrade options: the Eau Claire-Wheaton 161 kV line, the SW_Eau Claire-Alma 161 kV line, the Saratoga-Petenwel 138 kV line, and the East Krok-Kewaunee 138 kV line. All four facilities are constraints with either option.

1.8.2.4 A383 (250 MW MHEB-MISO to MP)

A383 is a request for 250 MW of network transmission service from MHEB-MISO to MP. With respect to request A383, no significantly affected facilities were identified for either of the transmission upgrade options.

1.8.2.5 A416 (50 MW MHEB-MISO to NSP)

A416 is a request for 50 MW of network transmission service from MHEB-MISO to NSP. Request A416 has a significant thermal impact on the facilities shown in Table 1-13.

With respect to request A416, both significantly affected facilities are common to both transmission upgrade options: the SW_Eau Claire-Alma 161 kV line and the Jackson 161/69 kV transformer. Both facilities are constraints with either option.

1.8.2.6 A417 (100 MW MHEB-MISO to WEC)

A417 is a request for 100 MW of network transmission service from MHEB-MISO to WEC. Request A417 has a significant thermal impact on the facilities shown in Table 1-14.

With respect to request A417, two significantly affected facilities are common to both transmission upgrade options: the Eau Claire-Wheaton 161 kV line and the Saratoga-Petenwel 138 kV line. These two facilities are constraints with either option.

Table 1-9: A388 Thermal Violations (200 MW MHEB-MISO to GRE)

Option 1

Monitored Branches	Owner	Rating	Pre TSR Loading (%)	Post TSR Loading (%)	DF (%)	Contingency
No significantly affected facilities						

Option 3

Monitored Branches	Owner	Rating	Pre TSR Loading (%)	Post TSR Loading (%)	DF (%)	Contingency
No significantly affected facilities						

Table 1-10: A351 Thermal Violations (30 MW MHEB-MISO to NSP)

Option 1

Monitored Branches	Owner	Rating	Pre TSR Loading (%)	Post TSR Loading (%)	DF (%)	Contingency
No significantly affected facilities						

Option 3

Monitored Branches	Owner	Rating	Pre TSR Loading (%)	Post TSR Loading (%)	DF (%)	Contingency
No significantly affected facilities						

Table 1-11: A380 Thermal Violations (500 MW MHEB-MISO to WPS)

Option 1

Monitored Branches	Owner	Rating	Pre TSR Loading (%)	Post TSR Loading (%)	DF (%)	Contingency
602021 EAU CLA5 161 602030 WHT 14 5 161 1	XEL	300	97.8	107.8	6.0	C:B_XEL_KING-EAU_CLA Open 601014 AS KING3 345 601028 EAU CL 3 345 1 Open 601028 EAU CL 3 345 602021 EAU CLA5 161 9
605663 SW_ECL 161 681543 ALMA 5 161 1	DPC	194	97.9	106.9	3.5	C:B_XEL_KING-EAU_CLA Open 601014 AS KING3 345 601028 EAU CL 3 345 1 Open 601028 EAU CL 3 345 602021 EAU CLA5 161 9
699240 SAR 138 138 699808 PETENWEL 138 1	ATC	72.2	98.3	137.3	5.6	C:ATC-ZN1-2 Open 601014 AS KING3 345 601028 EAU CL 3 345 1 Open 601028 EAU CL 3 345 699244 ARP 345 345 1
699240 SAR 138 138 699808 PETENWEL 138 1	ATC	72.2	90.5	127.9	5.4	C:ATC-ARP-OG2 Open 601028 EAU CL 3 345 699244 ARP 345 345 1 Open 698342 COC 69 69.0 699901 TIMBERWOLF 69.0 1 Open 680121 MAUSTON 69.0 698333 HLT 69 69.0 1 Open 680242 LUBLIN 69.0 680505 LAKEHEAD 69.0 1
699240 SAR 138 138 699808 PETENWEL 138 1	ATC	72.2	94.5	132.2	5.4	C:ATC-ARP-OG1 Open 601014 AS KING3 345 601028 EAU CL 3 345 1 Open 601028 EAU CL 3 345 699244 ARP 345 345 1 Open 698342 COC 69 69.0 699901 TIMBERWOLF 69.0 1 Open 680121 MAUSTON 69.0 698333 HLT 69 69.0 1 Open 680242 LUBLIN 69.0 680505 LAKEHEAD 69.0 1
699619 EAST KRK 138 699620 KEWAUNEE 138 1	ATC	272.6	87.8	101.2	7.3	C:699359 N APP 1 345 699630 KEWAUNEE 345 1

Table 1-11 (continued): A380 Thermal Violations (500 MW MHEB-MISO to WPS)

Option 3

Monitored Branches	Owner	Rating	Pre TSR Loading (%)	Post TSR Loading (%)	DF (%)	Contingency
602021 EAU CLA5 161 602030 WHT 14 5 161 1	XEL	300	97.9	108.1	6.1	C:B_XEL_KING-EAU_CLA Open 601014 AS KING3 345 601028 EAU CL 3 345 1 Open 601028 EAU CL 3 345 602021 EAU CLA5 161 9
605663 SW_ECL 161 681543 ALMA 5 161 1	DPC	194	96.4	104.8	3.3	C:B_XEL_KING-EAU_CLA Open 601014 AS KING3 345 601028 EAU CL 3 345 1 Open 601028 EAU CL 3 345 602021 EAU CLA5 161 9
699240 SAR 138 138 699808 PETENWEL 138 1	ATC	72.2	97.9	136.7	5.6	C:ATC-ZN1-2 Open 601014 AS KING3 345 601028 EAU CL 3 345 1 Open 601028 EAU CL 3 345 699244 ARP 345 345 1
699240 SAR 138 138 699808 PETENWEL 138 1	ATC	72.2	90.2	127.3	5.4	C:ATC-ARP-OG1 Open 601014 AS KING3 345 601028 EAU CL 3 345 1 Open 601028 EAU CL 3 345 699244 ARP 345 345 1 Open 698342 COC 69 69.0 699901 TIMBERWOLF 69.0 1 Open 680121 MAUSTON 69.0 698333 HLT 69 69.0 1 Open 680242 LUBLIN 69.0 680505 LAKEHEAD 69.0 1
699240 SAR 138 138 699808 PETENWEL 138 1	ATC	72.2	94.7	132.2	5.4	C:ATC-ARP-OG2 Open 601028 EAU CL 3 345 699244 ARP 345 345 1 Open 698342 COC 69 69.0 699901 TIMBERWOLF 69.0 1 Open 680121 MAUSTON 69.0 698333 HLT 69 69.0 1 Open 680242 LUBLIN 69.0 680505 LAKEHEAD 69.0 1
699619 EAST KRK 138 699620 KEWAUNEE 138 1	ATC	272.6	87.5	100.8	7.2	C:699359 N APP 1 345 699630 KEWAUNEE 345 1

Table 1-12: A383 Thermal Violations (250 MW MHEB-MISO to MP)

Option 1

Monitored Branches	Owner	Rating	Pre TSR Loading (%)	Post TSR Loading (%)	DF (%)	Contingency
No significantly affected facilities						

Option 3

Monitored Branches	Owner	Rating	Pre TSR Loading (%)	Post TSR Loading (%)	DF (%)	Contingency
No significantly affected facilities						

Table 1-13: A416 Thermal Violations (50 MW MHEB-MISO to NSP)

Option 1

Monitored Branches	Owner	Rating	Pre TSR Loading (%)	Post TSR Loading (%)	DF (%)	Contingency
605663 SW_ECL 161 681543 ALMA 5 161 1	DPC	194.0	107.9	110.1	8.7	C:B_XEL_KING-EAU_CLA Open 601014 AS KING3 345 601028 EAU CL 3 345 1 Open 601028 EAU CL 3 345 602021 EAU CLA5 161 9
602022 JACKSON5 161 605309 JACKCO 8 69.0 1	XEL	47.0	153.3	160.8	7.1	C:605292 MONROCO8 69.0 605298 SPARTA28 69.0 1
602022 JACKSON5 161 605309 JACKCO 8 69.0 1	XEL	47.0	131.0	137.5	6.2	C:605322 TREMVAL8 69.0 605328 BLAIR 8 69.0 1
602022 JACKSON5 161 605309 JACKCO 8 69.0 1	XEL	47.0	127.7	133.8	5.7	C:602029 TREMVAL5 161 605322 TREMVAL8 69.0 1
602022 JACKSON5 161 605309 JACKCO 8 69.0 1 ¹	XEL	47.0	101.2	107.0	5.5	** Base Case **

Note: Jackson 161-69 kV transformer overloads above 115% for several contingencies (worst three overloads listed)

Option 3

Monitored Branches	Owner	Rating	Pre TSR Loading (%)	Post TSR Loading (%)	DF (%)	Contingency
605663 SW_ECL 161 681543 ALMA 5 161 1	DPC	194.0	105.7	107.9	8.5	C:B_XEL_KING-EAU_CLA Open 601014 AS KING3 345 601028 EAU CL 3 345 1 Open 601028 EAU CL 3 345 602021 EAU CLA5 161 9
602022 JACKSON5 161 605309 JACKCO 8 69.0 1	XEL	47.0	152.7	160.2	7.1	C:605292 MONROCO8 69.0 605298 SPARTA28 69.0 1
602022 JACKSON5 161 605309 JACKCO 8 69.0 1	XEL	47.0	130.8	137.3	6.2	C:605322 TREMVAL8 69.0 605328 BLAIR 8 69.0 1
602022 JACKSON5 161 605309 JACKCO 8 69.0 1	XEL	47.0	127.7	133.8	5.7	C:602029 TREMVAL5 161 605322 TREMVAL8 69.0 1
602022 JACKSON5 161 605309 JACKCO 8 69.0 1	XEL	47.0	101.4	107.2	5.5	** Base Case **

Note: Jackson 161-69 kV transformer overloads above 115% for several contingencies (worst three overloads listed)

Table 1-14: A417 Thermal Violations (100 MW MHEB-MISO to WEC)

Option 1

Monitored Branches	Owner	Rating	Pre TSR Loading (%)	Post TSR Loading (%)	DF (%)	Contingency
602021 EAU CLA5 161 602030 WHT 14 5 161 1	XEL	300	102.8	104.2	4.4	C:B_XEL_KING-EAU_CLA Open 601014 AS KING3 345 601028 EAU CL 3 345 1 Open 601028 EAU CL 3 345 602021 EAU CLA5 161 9
699240 SAR 138 138 699808 PETENWEL 138 1	ATC	72.2	138.5	143.6	3.6	C:ATC-ZN1-2 Open 601014 AS KING3 345 601028 EAU CL 3 345 1 Open 601028 EAU CL 3 345 699244 ARP 345 345 1
699240 SAR 138 138 699808 PETENWEL 138 1	ATC	72.2	129.1	133.8	3.4	C:ATC-ARP-OG1 Open 601014 AS KING3 345 601028 EAU CL 3 345 1 Open 601028 EAU CL 3 345 699244 ARP 345 345 1 Open 698342 COC 69 69.0 699901 TIMBERWOLF 69.0 1 Open 680121 MAUSTON 69.0 698333 HLT 69 69.0 1 Open 680242 LUBLIN 69.0 680505 LAKEHEAD 69.0 1
699240 SAR 138 138 699808 PETENWEL 138 1	ATC	72.2	133.5	138.3	3.4	C:ATC-ARP-OG2 Open 601028 EAU CL 3 345 699244 ARP 345 345 1 Open 698342 COC 69 69.0 699901 TIMBERWOLF 69.0 1 Open 680121 MAUSTON 69.0 698333 HLT 69 69.0 1 Open 680242 LUBLIN 69.0 680505 LAKEHEAD 69.0 1

Table 1-14 (continued): A417 Thermal Violations (100 MW MHEB-MISO to WEC)

Option 3

Monitored Branches	Owner	Rating	Pre TSR Loading (%)	Post TSR Loading (%)	DF (%)	Contingency
602021 EAU CLA5 161 602030 WHT 14 5 161 1	XEL	300	103.1	104.6	4.5	C:B_XEL_KING-EAU_CLA Open 601014 AS KING3 345 601028 EAU CL 3 345 1 Open 601028 EAU CL 3 345 602021 EAU CLA5 161 9
699240 SAR 138 138 699808 PETENWEL 138 1	ATC	72.2	137.9	142.8	3.6	C:ATC-ZN1-2 Open 601014 AS KING3 345 601028 EAU CL 3 345 1 Open 601028 EAU CL 3 345 699244 ARP 345 345 1
699240 SAR 138 138 699808 PETENWEL 138 1	ATC	72.2	128.4	133.1	3.4	C:ATC-ARP-OG1 Open 601014 AS KING3 345 601028 EAU CL 3 345 1 Open 601028 EAU CL 3 345 699244 ARP 345 345 1 Open 698342 COC 69 69.0 699901 TIMBERWOLF 69.0 1 Open 680121 MAUSTON 69.0 698333 HLT 69 69.0 1 Open 680242 LUBLIN 69.0 680505 LAKEHEAD 69.0 1
699240 SAR 138 138 699808 PETENWEL 138 1	ATC	72.2	133.5	138.2	3.4	C:ATC-ARP-OG2 Open 601028 EAU CL 3 345 699244 ARP 345 345 1 Open 698342 COC 69 69.0 699901 TIMBERWOLF 69.0 1 Open 680121 MAUSTON 69.0 698333 HLT 69 69.0 1 Open 680242 LUBLIN 69.0 680505 LAKEHEAD 69.0 1



MTEP Projects Applied from MOD

Transmission Owner	MTEP Project ID	Project Name	MTEP Appendix
ATC LLC	345	Morgan - Werner West 345 kV line (includes Clintonville-Werner West 138)	A
XEL	1486	Mary Lake - City of Buffalo 69 kV line 116 MVA	A
XEL/SMP		SMP-GRANDMEADOW-WF	B
XEL	2119	G417	A
ITC	905	Marysville Decommissioning	A
ITCM	1758	Beaver Channel-2nd Ave 69kV	A
ITCM	1755	Washington-Hills 69kV Rebuild	A
ITCM	1752	Jefferson Co 69kV Cap banks	A
ITCM	1751	Jefferson Co 161/69kV	A
ITCM	1289	Marshalltown - Toledo - Belle Plaine - Stoney Point 115 kV line rebuild	A
SMP	1367	Lake City load serving upgrades	A
ATC LLC	352	Cranberry-Conover 115 kV and Conover-Plains conversion to 138 kV	A
ITCM	1522	6th Street - Beverly	A
ATC LLC	570	Rock River-Bristol-Elkhorn conversion to 138 kV	A
ATC LLC	177	Gardner Park-Highway 22 345 kV line projects	A
ATC LLC	345	Morgan - Werner West 345 kV line (includes Clintonville-Werner West 138)	A
ATC LLC	1268	Cap banks at Artesian and Kilbourn	A
ATC LLC	1677	Uprate Chandler-Cornell 69 kV line	A
XEL	1371	Black Dog - Wilson 115 kV #2 Reconductor	A
XEL	1457	G287, 37642-03. Upgrades for G287	A
XEL	1548	La Crosse Area Capacitor banks	A
XEL	385	Xcel Energy Wind 425-825 MW project	A
XEL	1489	Woodbury - Tanners Lake upgrade	A
ITCM	1341	Replace two Hazleton 161/69 kV transformers	A
ITCM	1287	Replace Salem 345/161 kV transformer with 448 MVA unit	A
XEL	1487	Somerset - Stanton 69 kV line 84 MVA	A
XEL	1368	Three Lakes 115/69 kV substation	A
XEL	1548	La Crosse Area Capacitor banks	A
XEL	1455	G238, 37642-02, Increase of generating capacity at Riverside Generating Plant	A
XEL	1373	Ft. Ridgeley - Searles Jct 115 new line and Searles Jct - New Ulm 69 Reconductor	A
XEL	1457	G287, 37642-03. Upgrades for G287	A
ATC LLC	1279	North Beaver Dam 49 MVAR cap bank	A

Transmission Owner	MTEP Project ID	Project Name	MTEP Appendix
ITC	1488	Break up 3-ended Prizm-Proud-Placid 120 kV line	A
ATC LLC	345	Morgan - Werner West 345 kV line (includes Clintonville-Werner West 138)	A
XEL	552	Ironwood 92/34.5 kV transformer #2	A
ATC LLC	1681	Uprate North Lake Geneva-Lake Geneva 69 kV line	A
ATC LLC	1944	G550 Uprate Concord generators #3 & #4	C
ATC LLC	1682	Rebuild Crivitz-High Falls Dbl Ckt 69 kV line	A
ATC LLC	1679	Richland Center Olson sub and Brewer Sub Capacitor banks	A
OTP/MPC	2091	Cass Lake 115/69/41.6 kV sub	A
OTP	2092	South Cascade 115 kV Addition	A
MP/GRE	1022	Badoura-Long Lake 115 kV line	A
ATC LLC	1555	Perkins Capacitor Banks	A
ITC	1871	Hurst	A
XEL/GRE	1545	Mankato 115 kV loop	A
ATC LLC	1676	L'Anse Capacitor Bank	A
ATC LLC	1553	Hiawatha 138kV Capacitor Bank	A
ATC LLC	352	Cranberry-Conover 115 kV and Conover-Plains conversion to 138 kV	A
ATC LLC	339	Lake Mills Transmission-Distribution interconnection	A
ATC LLC	339	Lake Mills Transmission-Distribution interconnection	A
ATC LLC	345	Morgan - Werner West 345 kV line (includes Clintonville-Werner West 138)	A
OTP	1792	Mapleton - Buffalo 115 kV line addition	A
ATC LLC	1667	Pine River substation Upgrades	A
ATC LLC	177	Gardner Park-Highway 22 345 kV line projects	A
GRE	599	Crooked Lake - Enterprise Park 115 kV line	A
XEL	1956	Blue Lake - Wilmarth 345 kV line capacity upgrade	A
ITC	1870	Clyde	A
ATC LLC	345	Morgan - Werner West 345 kV line (includes Clintonville-Werner West 138)	A
ITCM	1644	Grand Junction 24 MVAR Cap Bank	A
ITCM	1643	Anita 24 MVAR Cap Bank	A
ITCM	1739	Arnold-Vinton-Dysart-Washburn 161kV Reconductor	A
ITCM	1641	OGS 50 MVAR Cap Bank	A
ITCM	1619	Grnd Mnd 161-69kV 2nd Xfmr & 161kV loop	A
MP	277	Badoura Project: Pine River - Pequot Lakes 115 kV line	A
MP/GRE	1021	Embarass to Tower 115 kV Line	A
ATC LLC	1268	Cap banks at Artesian and Kilbourn	A
ATC LLC	1938	G366, 37909-02 Randolph Wind Farm	C
ATC LLC	1143	G282, 37628-02	C
ATC LLC	2057	Warrens T-D	A
ATC LLC	1945	Upgrade Sheekskin Capacitor 69-kV Bank	A
ATC LLC	1680	Uprate Walworth-North Lake Geneva 69 kV line	A
XEL	1959	Yankee Doodle interconnection	A
ATC LLC	1939	G588, Marshfield CT	C
MP/GRE	1022	Badoura-Long Lake 115 kV line	A

Transmission Owner	MTEP Project ID	Project Name	MTEP Appendix
ATC LLC	352	Cranberry-Conover 115 kV and Conover-Plains conversion to 138 kV	A
XEL	1368	Three Lakes 115/69 kV substation	A
ATC LLC	352	Cranberry-Conover 115 kV and Conover-Plains conversion to 138 kV	A
ATC LLC	1683	Rebuild Sunset Point-Pearl Ave 69 kV line	A
ITC	1873	Tahoe	A
Midwest ISO	2194	MTEP08 Reference Future EHV Overlay - Toledo to Montgomery	A
ITCM	1342	Lewis Fields 161 kV substation which taps the SwampFX - Coggon 115 kV line	A
ATC LLC	1267	New Oak Ridge-Verona 138-kV line and a 138/69-kV transformer at Verona	A
XEL	56	Chisago - Apple River	A
OTP	973	Big Stone II Generation Project	B
XEL	1953	St. Cloud - Sauk River 115 kV line upgrade	A
XEL	1961	Lake Emily Capacitor bank	A
MP	1482	Pepin Lake 115/34.5 - Transformer 115/34.5 kV 39 MVA	A
OTP/MPC	971	Winger 230/115 kV Transformer Upgrade	A
ITCM	1288	Replace Hazleton 345/161 kV transformer #1 with 335 MVA unit	A
ITCM	1289	Marshalltown - Toledo - Belle Plaine - Stoney Point 115 kV line rebuild	A
ITCM	1618	Hrn Lk-Lkfld 161kV Ckt 1 Rbld	A
XEL	1960	Traverse - St. Peter upgrade	A
XEL	675	Rebuild Westgate to Scott County 69 kV to 115 kV	A
XEL	1285	Build 18 miles 115 kV line from Glencoe - West Waconia	A
XEL	2109	G609	A
XEL	1954	Cherry Creek - Split Rock 115 kV line saperation	A
GRE/OTP	1033	Silver Lake 230/41.6 kV transformer	A
OTP	973	Big Stone II Generation Project	B
ITC	907	Goodison Station (Oakland)	A
ITCM	1345	Replace the limiting facility of CTs and conductor inside the substations for Quad Cities-Rock Creek-Salem 345 kV line	A
ITCM	1340	Hazleton - Salem 345 kV line with a 2nd Salem 345/161 kV 448 MVA transformer.	A
ITC	692	Bismark-Troy 345 kV line	A
OTP	973	Big Stone II Generation Project	B
ATC LLC	1470	G483	A
XEL	1957	New 161/69 kV Sub SW of Eau Claire where Alma – Elk Mound 161 kV intersects Shawtown – Naples 69 kV line. Rebuild 69 kV London/Madison to new substation. New 69 kV from new substation - DPC Union Sub. New 69 kV to DPC Brunswick Sub	A
OTP	973	Big Stone II Generation Project	B
MPC/XEL/OTP/MP	279	Bemidji-Grand Rapids 230 kV Line	A
XEL	1958	Stone Lake-Edgewater 161 kV line. A new radial 161 kV line and substation in Sawyer County, Wisconsin	A
ATC LLC	1617	G527	A
ATC LLC	574	Monroe County - Council Creek 161 kV line projects	A
ATC LLC	574	Monroe County - Council Creek 161 kV line projects	A
ATC LLC	356	Rockdale-West Middleton 345 kV	A

Transmission Owner	MTEP Project ID	Project Name	MTEP Appendix
OTP	973	Big Stone II Generation Project	B
GRE, XEL, OTP, MP, MRES	286	Fargo, ND - St Cloud/Monticello, MN area 345 kV project	A
XEL	1957	New 161/69 kV Sub SW of Eau Claire where Alma – Elk Mound 161 kV intersects Shawtown – Naples 69 kV line. Rebuild 69 kV London/Madison to new substation. New 69 kV from new substation - DPC Union Sub. New 69 kV to DPC Brunswick Sub	A
XEL/GRE	1203	Brookings, SD - SE Twin Cities 345 kV project	B
OTP	973	Big Stone II Generation Project	B
XEL, DPC, RPU, SMP, WPPi	1024	SE Twin Cities - Rochester, MN - LaCrosse, WI 345 kV project	A
OTP	585	Pelican Rapids 115 kV Line Uprate	B
ATC LLC	1463	Twin_Creeks-G384	N/A
ITCM	1645	Leon-1645_69kV_7MVAR	N/A
ITCM	1772	N_Cntrville_69kV-1772_7MVA	N/A
WAPA, BEPC	Correction	Su2009+-SplitWess	N/A
GRE	Network	KRMRLK(53801)	N/A
XEL	1380	WWACONIA-SCOTT	N/A

N/A – These projects have been withdrawn and no longer appear in MTEP Appendix A/B.

Appendix
B

Transmission Upgrade Options

Table B-1: Modeling Parameters

Facility	R (pu)	X (pu)	B (pu)	Rate A (MVA)	Rate B (MVA)
Dorsey – Maple River 500 kV line with 50% series compensation	0.00290	0.04830	4.30	1732	1905
		-0.02415		1732	2165
Maple River – Helena 500 kV line with 50% series compensation	0.00252	0.04200	3.74	1732	1905
		-0.02100		1732	2165
Dorsey – King 500 kV line with 50% series compensation	0.00600	0.10700	10.00	1732	1905
		-0.05350		1732	2165
500/345 kV, 1200 MVA Transformer One at Maple River (Option1) Two at Helena (Option 1) Two at King (Option 3)	0.000050	0.004700		1200	1200

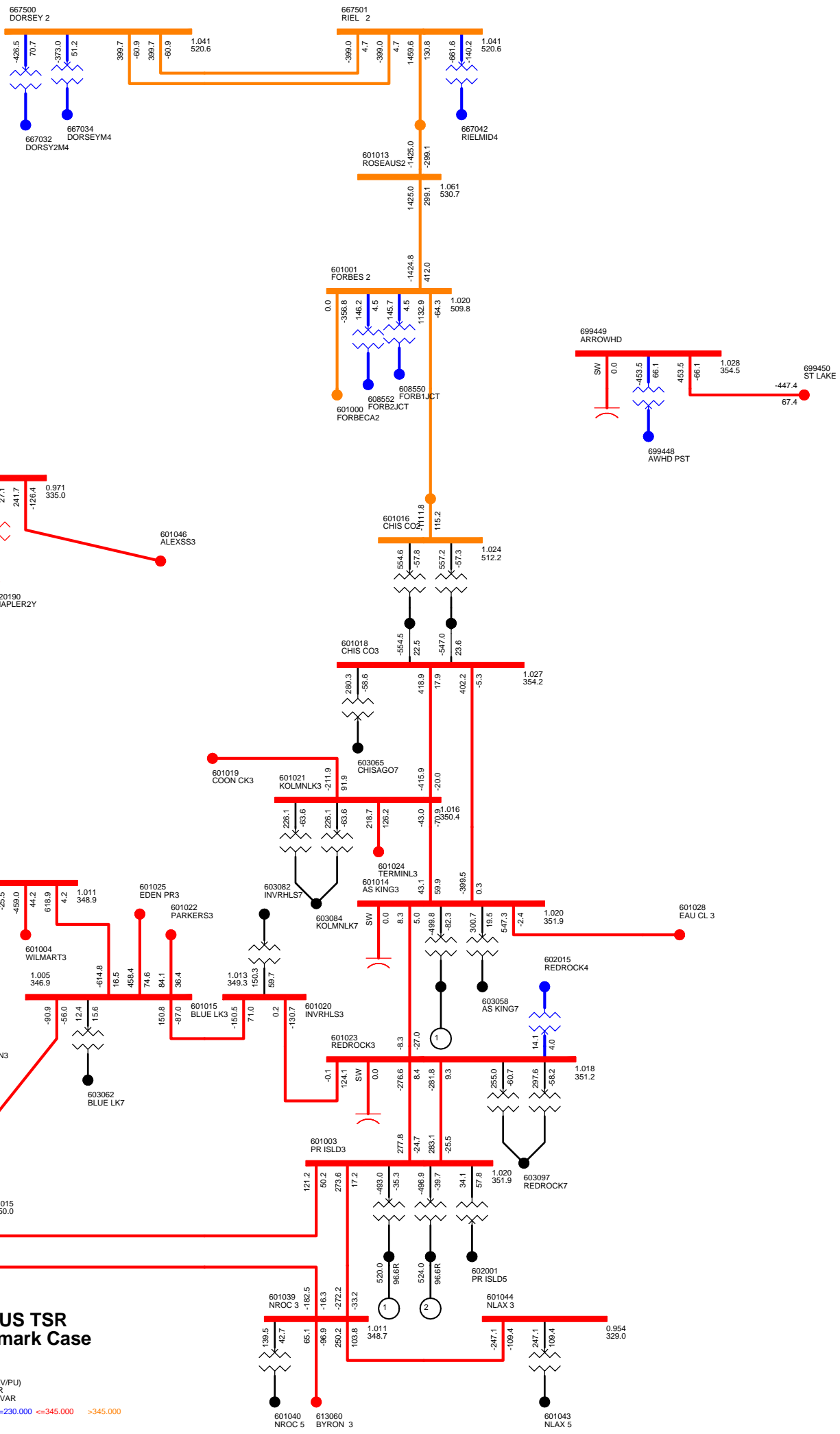

MH-US TSR Benchmark Case

Bus - VOLTAGE (KV/PU)
 Branch - MW/MVAR
 Equipment - MW/MVAR
 KV: <=161.000 <=230.000 <=345.000 >345.000

MH-US TSR Transmission Upgrade Option 1

Bus - VOLTAGE (KV/PU)
Branch - MW/MVAR
Equipment - MW/MVAR
KV: <=161.000 <=230.000 <=345.000 >345.000

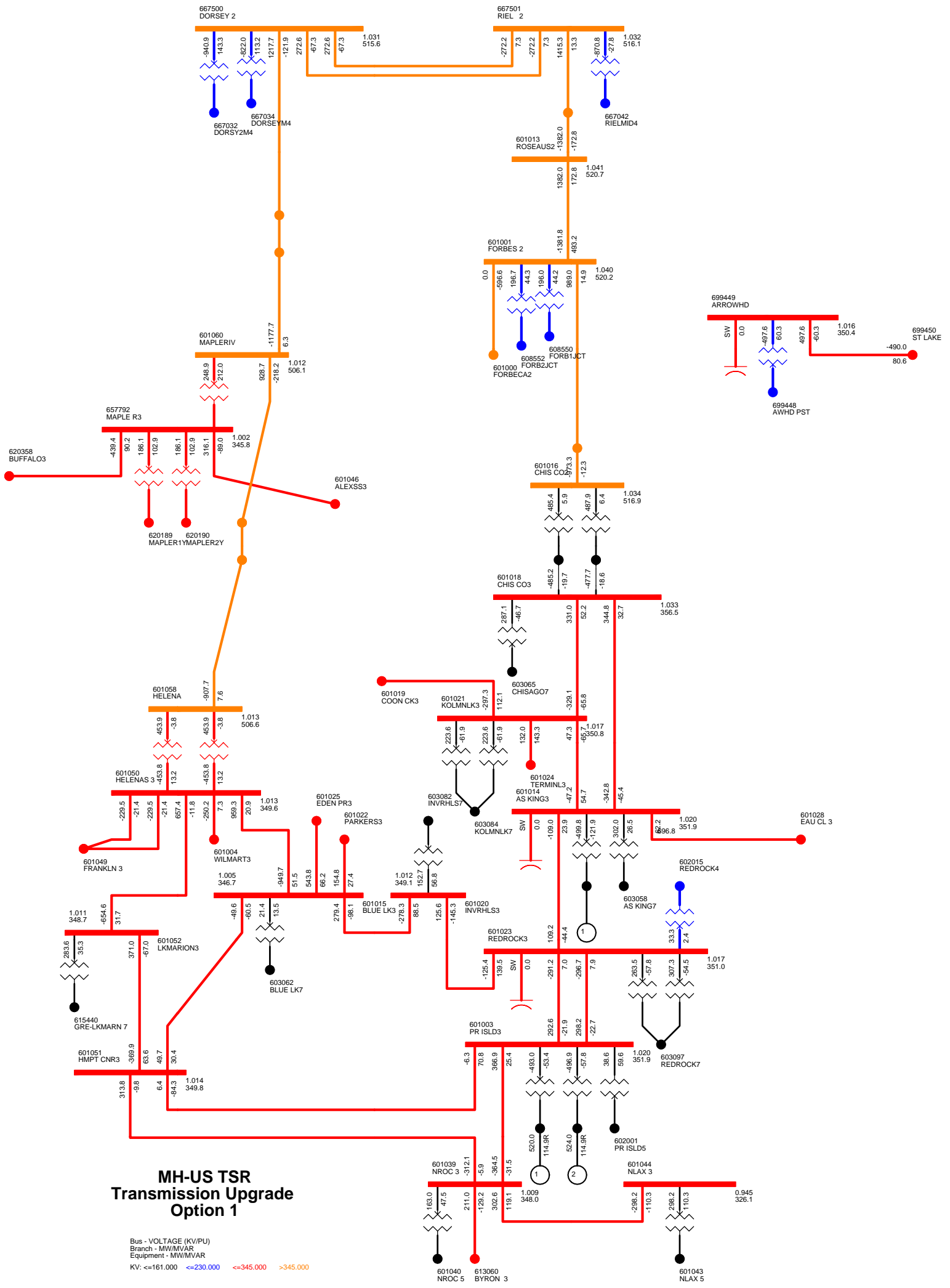

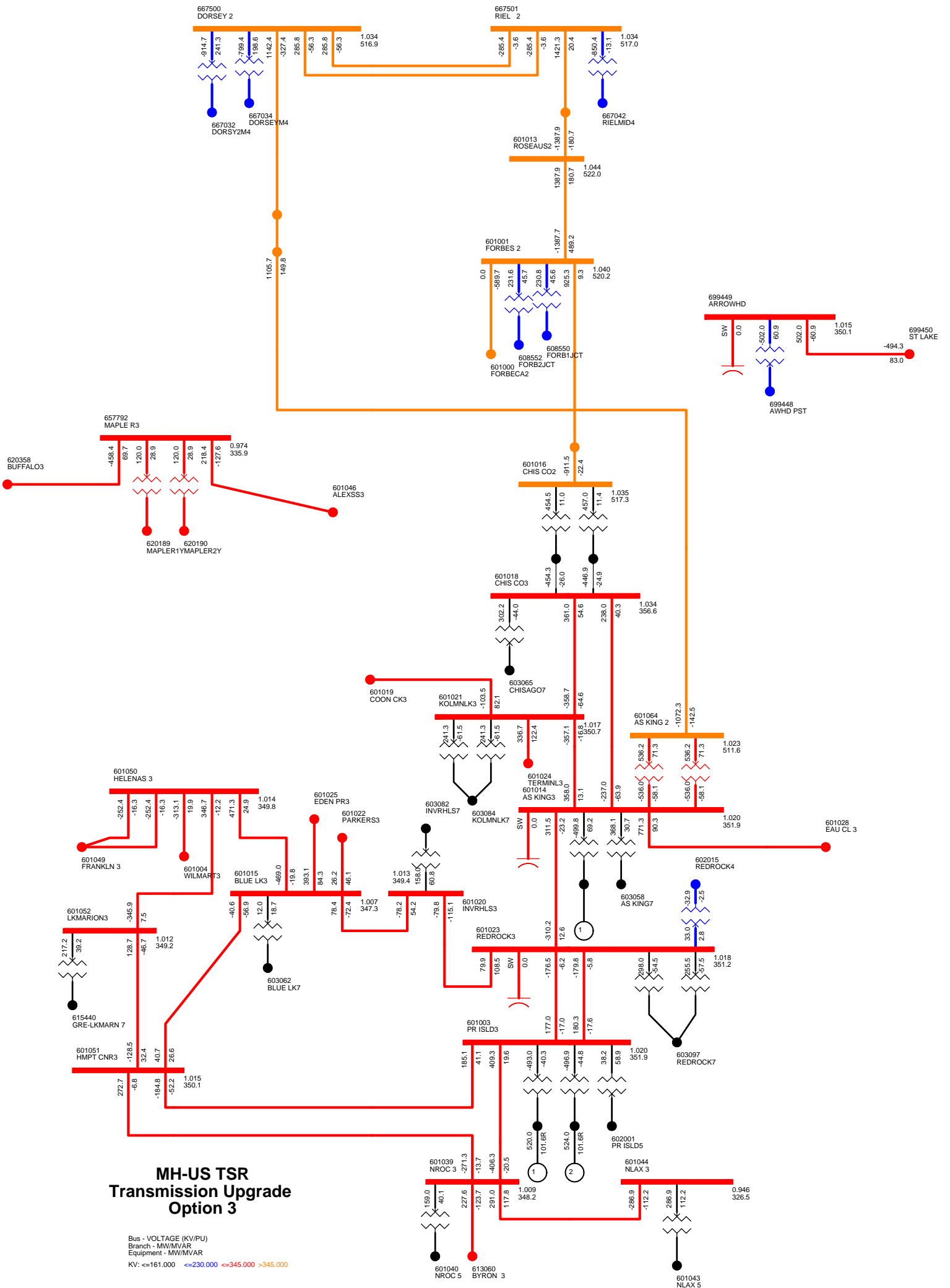

MH-US TSR Transmission Upgrade Option 3

Bus - VOLTAGE (KV/PU)
Branch - MW/MVAR
Equipment - MW/MVAR
KV: ≤ 161.000 ≤ 230.000 ≤ 345.000 > 345.000



Network Analysis Results

Table C-1: Network Loss Analysis Results

Area	Benchmark Case Losses	Option 1 Study Case		Option 3 Study Case	
		Losses	Difference	Losses	Difference
295 WEC	158.6 MW	162.8 MW	4.2 MW	163.2 MW	4.6 MW
	2663.1 MVAR	2705.7 MVAR	42.6 MVAR	2711.1 MVAR	48.0 MVAR
600 XEL	413.5 MW	442.2 MW	28.7 MW	427.7 MW	14.2 MW
	4297.5 MVAR	4498.2 MVAR	200.7 MVAR	4388.7 MVAR	91.2 MVAR
608 MP	105.7 MW	105.5 MW	-0.2 MW	106.2 MW	0.5 MW
	1342.9 MVAR	1366.2 MVAR	23.3 MVAR	1372.8 MVAR	29.9 MVAR
613 SMMPA	1.6 MW	2.1 MW	0.5 MW	2.0 MW	0.4 MW
	16.8 MVAR	21.6 MVAR	4.8 MVAR	20.2 MVAR	3.4 MVAR
615 GRE	95.2 MW	95.9 MW	0.7 MW	93.8 MW	-1.4 MW
	1840.8 MVAR	1824.9 MVAR	-15.9 MVAR	1776.4 MVAR	-64.4 MVAR
620 OTP	114.4 MW	115.0 MW	0.6 MW	113.9 MW	-0.5 MW
	1175.1 MVAR	1161.6 MVAR	-13.5 MVAR	1169.0 MVAR	-6.1 MVAR
627 ALTW	99.5 MW	102.0 MW	2.5 MW	100.2 MW	0.7 MW
	1026.6 MVAR	1031.6 MVAR	5.0 MVAR	1023.3 MVAR	-3.3 MVAR
635 MEC	115.2 MW	118.4 MW	3.2 MW	116.4 MW	1.2 MW
	1319.4 MVAR	1336.5 MVAR	17.1 MVAR	1322.9 MVAR	3.5 MVAR
652 WAPA	225.0 MW	229.6 MW	4.6 MW	228.4 MW	3.4 MW
	2560.5 MVAR	2605.2 MVAR	44.7 MVAR	2600.8 MVAR	40.3 MVAR
667 MH	335.8 MW	433.8 MW	98.0 MW	436.1 MW	100.3 MW
	5214.6 MVAR	7173.7 MVAR	1959.1 MVAR	7184.0 MVAR	1969.4 MVAR
680 DPC	76.1 MW	85.7 MW	9.6 MW	82.2 MW	6.1 MW
	443.4 MVAR	500.0 MVAR	56.6 MVAR	483.0 MVAR	39.6 MVAR

Area	Benchmark Case Losses	Option 1 Study Case		Option 3 Study Case	
		Losses	Difference	Losses	Difference
694 ALTE	118.3 MW	129.1 MW	10.8 MW	128.5 MW	10.2 MW
	1123.3 MVAR	1198.4 MVAR	75.1 MVAR	1194.0 MVAR	70.7 MVAR
696 WPS	77.2 MW	89.8 MW	12.6 MW	90.2 MW	13.0 MW
	807.5 MVAR	884.2 MVAR	76.7 MVAR	895.2 MVAR	87.7 MVAR
697 MGE	14.0 MW	13.9 MW	-0.1 MW	13.9 MW	-0.1 MW
	215.5 MVAR	214.6 MVAR	-0.9 MVAR	214.5 MVAR	-1.0 MVAR
698 UPPC	8.0 MW	7.9 MW	-0.1 MW	7.9 MW	-0.1 MW
	27.9 MVAR	28.0 MVAR	0.1 MVAR	27.9 MVAR	0.0 MVAR
Network Upgrade Facilities	0.0 MW	61.3 MW	61.3 MW	70.4 MW	70.4 MW
	0.0 MVAR	549.2 MVAR	549.2 MVAR	765.1 MVAR	765.1 MVAR
TOTALS	1958.1 MW	2195.1 MW	237.0 MW	2181.1 MW	223.0 MW
	24076.1 MVAR	27100.8 MVAR	3024.7 MVAR	27150.3 MVAR	3074.2 MVAR

Table C-2: Combined Impact of TSRs and Transmission Upgrade Options on SUPK Case Thermal Violations, Significantly Affected Facilities

** From bus	** ** To bus	** CKT	Owner	Rating (MVA)	Benchmark Case Loading (%)	Option 1 Study Case		Option 3 Study Case		Contingency
						Loading (%)	DF (%)	Loading (%)	DF (%)	
699240 SAR 138	138 699808 PETENWEL	138 1	ATC	72	97.4	143.6	3.0	142.8	2.9	C:ATC-ZN1-2 Open 601014 AS KING3 345 601028 EAU CL 3 345 1 Open 601028 EAU CL 3 345 699244 ARP 345 345 1
699240 SAR 138	138 699808 PETENWEL	138 1	ATC	72.2	88.9	133.8	2.9	133.1	2.8	C:ATC-ARP-OG1 Open 601014 AS KING3 345 601028 EAU CL 3 345 1 Open 601028 EAU CL 3 345 699244 ARP 345 345 1 Open 698342 COC 69 69.0 699901 TIMBERWOLF 69.0 1 Open 680121 MAUSTON 69.0 698333 HLT 69 69.0 1 Open 680242 LUBLIN 69.0 680505 LAKEHEAD 69.0 1
699240 SAR 138	138 699808 PETENWEL	138 1	ATC	72.2	91.7	138.3	3.0	138.2	3.0	C:ATC-ARP-OG2 Open 601028 EAU CL 3 345 699244 ARP 345 345 1 Open 698342 COC 69 69.0 699901 TIMBERWOLF 69.0 1 Open 680121 MAUSTON 69.0 698333 HLT 69 69.0 1 Open 680242 LUBLIN 69.0 680505 LAKEHEAD 69.0 1
699619 EAST KRK	138 699620 KEWAUNEE	138 1	ATC	273	87.6	100.9	3.2	100.5	3.1	699359 N APP 1 345 699630 KEWAUNEE 345 1
602021 EAU CLA5	161 602030 WHT 14 5	161 1	XEL	300	95.0	104.2	2.4	104.6	2.5	C:B_XEL_KING-EAU_CLA Open 601014 AS KING3 345 601028 EAU CL 3 345 1 Open 601028 EAU CL 3 345 602021 EAU CLA5 161 9
605663 SW_ECL	161 681543 ALMA 5	161 1	DPC	194	92.8	111.2	3.2	108.8	2.7	C:B_XEL_KING-EAU_CLA Open 601014 AS KING3 345 601028 EAU CL 3 345 1 Open 601028 EAU CL 3 345 602021 EAU CLA5 161 9
602022 JACKSON5	161 605309 JACKCO 8	69.0 1	XEL	47	96.0	107.6	0.5	107.8	0.5	** Base Case **
602022 JACKSON5	161 605309 JACKCO 8	69.0 1	XEL	47.0	149.4	161.1	0.5	160.5	0.5	605292 MONROC08 69.0 605298 SPARTA28 69.0 1
602022 JACKSON5	161 605309 JACKCO 8	69.0 1	XEL	47.0	125.0	138.3	0.6	138.1	0.5	605322 TREMVAL8 69.0 605328 BLAIR 8 69.0 1
602022 JACKSON5	161 605309 JACKCO 8	69.0 1	XEL	47.0	122.1	134.4	0.5	134.4	0.5	602029 TREMVAL5 161 605322 TREMVAL8 69.0 1
667048 LETELER4	230 657752 DRAYTON4	230 1	OTP	460.5	63.2	100.9	15.4	98.7	14.4	MH-US-NEW-500KV-TIE

Note: Jackson 161-69 kV transformer overloads above 115% for several contingencies (worst three overloads listed)